

Description

Drawing nr. 122-657838

Semi-Automatic production

Crane loading & unloading

Cases based on 4 freezers

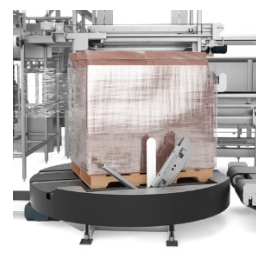
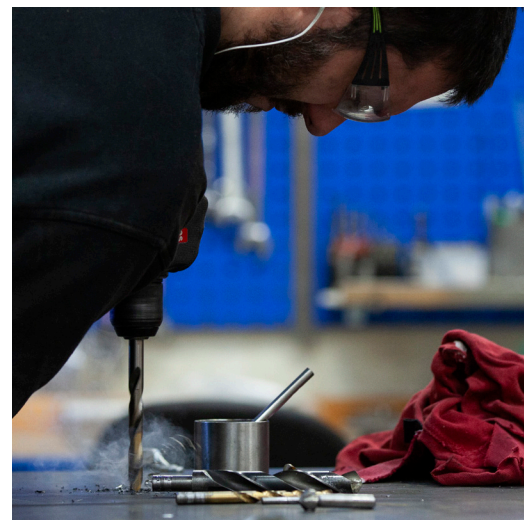
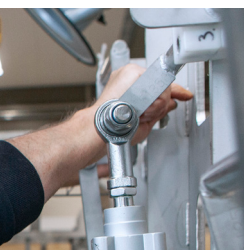
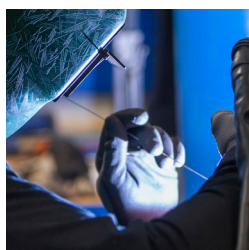

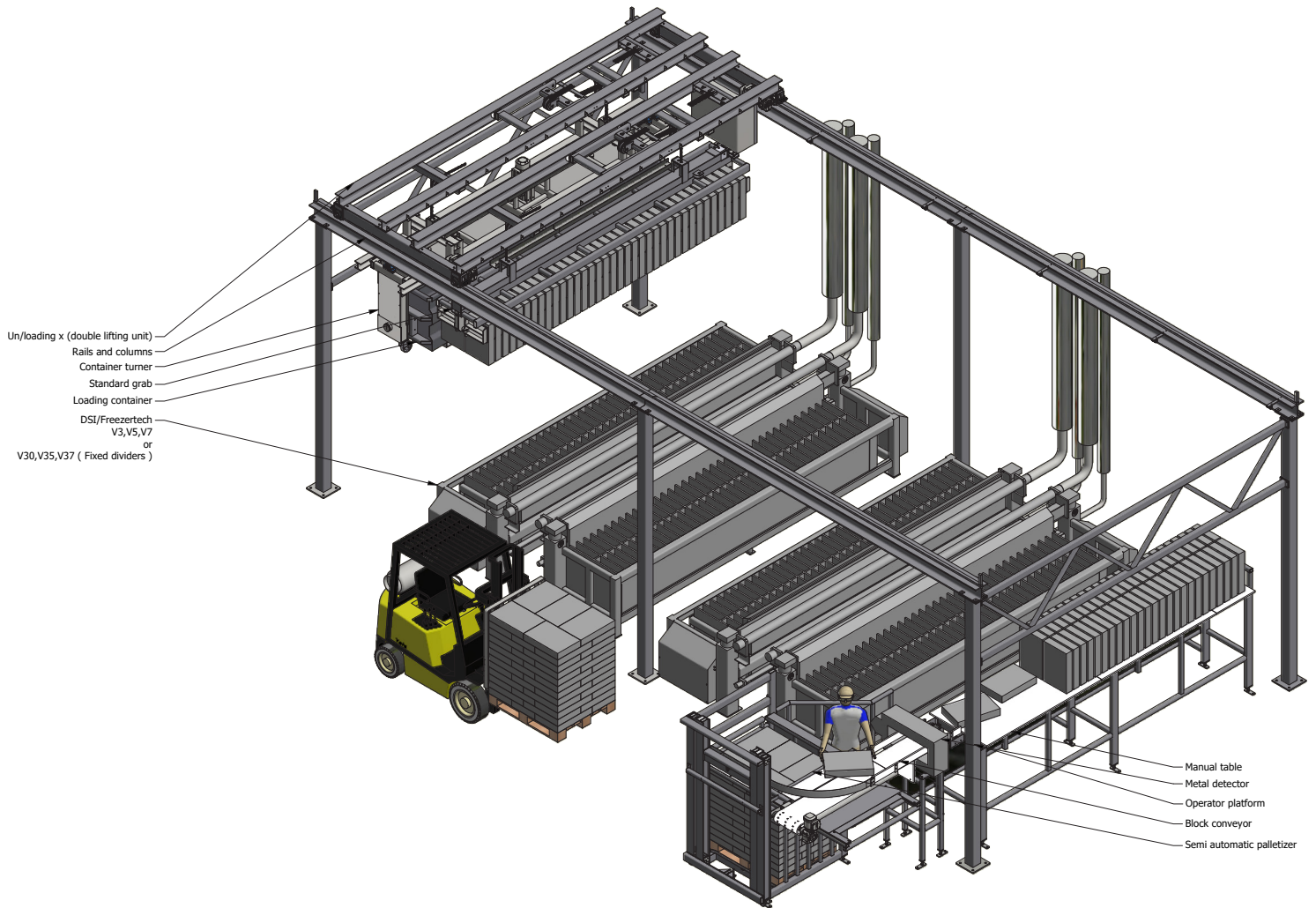

Semi-Automatic Palletizer system

*Semi automatic production with manual onloading table
and semi automatic palletizer.*

Cases based on 4 Freezers

V3 36/75 Nh3 -38° C

Cycle time 120 min

Approx 74 Ton/24 hours

Block size 1070x535x75 mm

V5 36/75 Nh3 -38° C

Cycle time 120 min

Approx 62 Ton/24 hours

Block size 600x400x75 mm

V7 36/75 Nh3 -38° C

Cycle time 120 min

Approx 66 Ton/24 hours

Block size 510x500x75 mm

SEAFOOD

MDM

LIQUIDS /SLURRY

ORGANS

Drawing nr. 122-657838



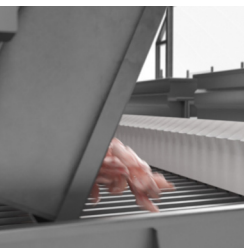
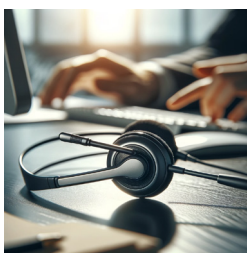
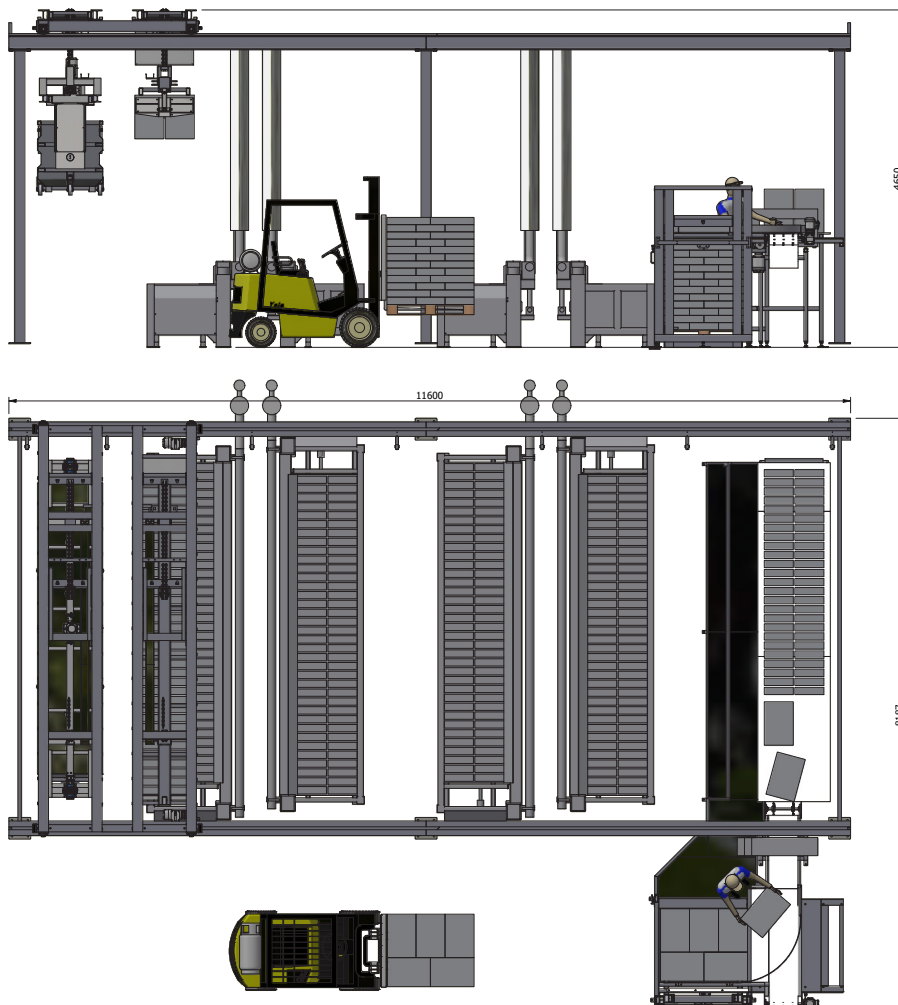

Worldwide **Service & support**

Get in touch with the people behind Erlinord.
We're here to help you find the right solutions.

www.erlinord.com



Thomas Uldall Jørgensen
CEO/ Part owner
+45 20718820
tuj@erlinord.com



Lasse K. Jensen
Spare parts and service
+45 2262 5143
aftersales@erlinord.com

