

Service Agreement

Extend equipment lifecycle



Service & Spare parts

Even the best equipment require regular service and neglecting that can consequently prove to be costly. Our service agreements will minimize production downtime, suit your operation and budget.

Onsite spare parts kit

Optimized spare parts kits is a profitable investment to avoid unplanned downtime, critical situations, components natural wear and tear. In close collaboration, we design a unique & optimized spare parts kit for you, with the most critical components at hand to keep your production up and running at all times.

With optimized spare parts kits you can access:

- High quality spare parts
- Quick service or repair
- Assistance, diagnostic and remote troubleshooting
- Extended equipment lifetime
- Advice on stock and re-stock optimization
- Package can be consolidated with new equipment

Auxiliary equipment

Auxiliary equipment is designed to streamline your production in a highly hygienic and efficient manner

Loading solutions

Loading equipment is designed according to the latest developments and technological advances

Unloading solutions

Customized systems ensure fast and simple unloading, and facilitate a very large capacity helping you to boost

Packaging solutions

Our systems guarantee extremely high levels of quality and safety for high-speed palletizing and packaging

Service agreements

Provide you with

- Highly skilled and dedicated specialists
- Minimized downtime
- Preventative inspection
- Extended equipment lifecycle
- Maintained high safety standard
- Environmental responsibility
- Genuine spare parts
- Discount on spare parts
- Discount on labour costs

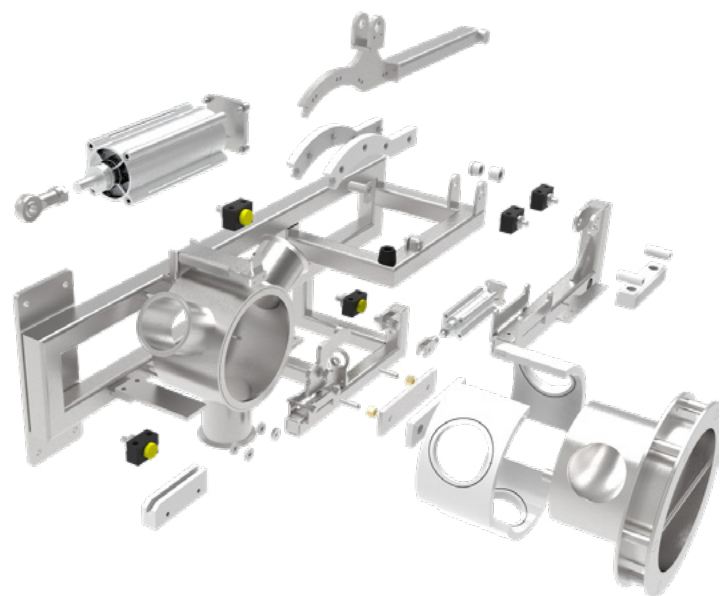

Service agreements

Standard service program

- ▶ 1 visit per year where we will go through your system
1 technician, 2 days onsite og 10 hours. *
- ▶ Training of operators
- ▶ Checkup, report with suggest of repair
- ▶ Service on equipment

Expected services
provided during a visit

- Emergency system
- Load chain and chain wheels inspection
- Hydraulic functions
- Pneumatic functions
- Oversee production

Plus service program

- ▶ 2 visit per year where we will go through your system
1 technician, 2 days onsite og 10 hours. *
- ▶ Training of operators and maintenance staff
- ▶ Checkup, report with suggest of repair
- ▶ Service on equipment Telephone or teams support (In normal opening
hours) 07-16 CET time)
- ▶ Fixed price on repair man-hours
- ▶ Discount on mechanical and electrical upgrades
- ▶ Discount on Troubleshooting on PLC through VPN (if you have one)
- ▶ Free software updates

Expected services
provided during a visit

- Hydraulic service on cranes and palletizing system
- Load chain and chain wheels inspection
- Pneumatic filters replacement
- Lubrication of chains and bearings
- Systematic maintenance chart with constitutions and
suggest for next visit.
- Test of emergency system
- Test of all machine movements
- Test of equipment in production mode

* **Notification:** Travel and accommodation costs are included in the price if the customer provides at least 12 weeks' notice for scheduling service visits.
If less than 12 weeks' notice is given, additional and unforeseen costs may apply.

Spare parts program

Hydraulic cylinders
Various hydraulic hoses for the handling equipment
Various hydraulic parts for the hydraulic units
Sensors and photocells
PLC and HMI (programmed)
Various gearmotors
Remote system for crane

Various parts for the wrapper
Various parts for the electrical cabinet
Robot coat and tooling parts
Load chain and chain wheels
Load cells
Various parts for the pneumatic system

Worldwide Service & support

Get in touch with the people behind Erlinord.
We're here to help you find the right solutions.

www.erlinord.com

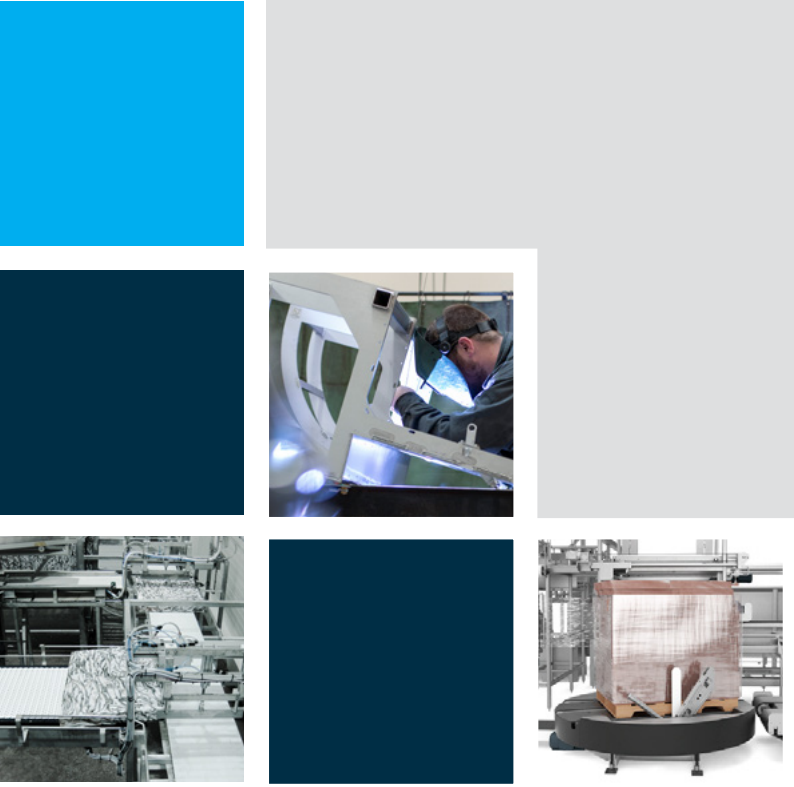

We hope you will enjoy our service and support at any time.
We are looking forward to hearing from you soon.
All the best,

Erlinord Automation

Contact Information

Erlinord Automation

Tysklandsvej 4, 7100 Vejle - Denmark
info@erlinord.com

Available Monday to Friday
from 8.00 AM to 16.00PM (CET)

Reach out to us at

+45 75 88 20 88



Lasse K. Jensen
Spare parts and service
+45 2262 5143
aftersales@erlinord.com



Thomas Uldall Jørgensen
CEO/ Part owner
+45 20718820
tuj@erlinord.com



ERLIN RD
AUTOMATION