

# ERLIN RD

*AUTOMATION*

## Custom Solutions

Product Line Inspiration

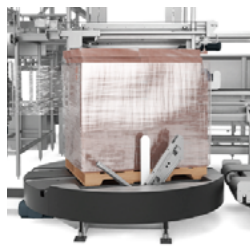
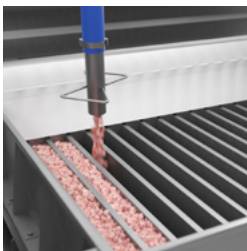
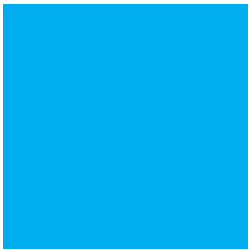
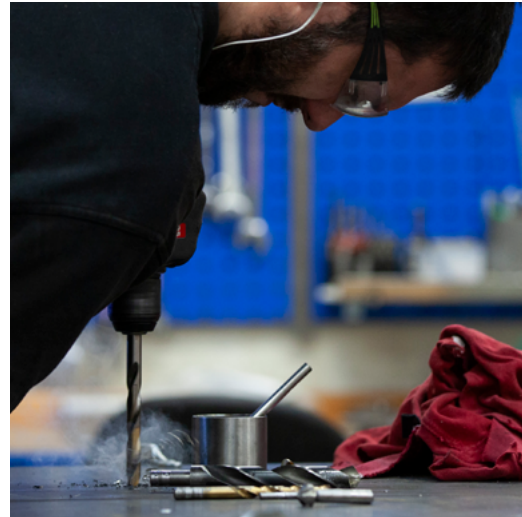
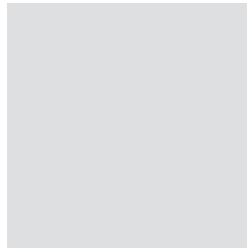

# Index

## Semi-Automatic production

SEAFOOD MDM LIQUIDS /SLURRY ORGANS

Drawing nr. 122-657838

## Semi-Automatic production

MDM SLURRY

Drawing nr. 122-657843

## Semi-Automatic production

SEAFOOD MDM LIQUIDS /SLURRY ORGANS

Drawing nr. 122-659020

## Semi-Automatic production

SEAFOOD MDM LIQUIDS /SLURRY ORGANS /MEAT

Drawing nr. 122-659023

## Semi-Automatic production

SEAFOOD MDM LIQUIDS /SLURRY ORGANS /MEAT

Drawing nr. 122-657765

## Full-Automatic production

MDM LIQUIDS /SLURRY

Drawing nr. 122-656856

## Full-Automatic production

MDM LIQUIDS /SLURRY

Drawing nr. 20-650448

## Automatic production

SEAFOOD MDM SLURRY ORGANS /MEAT

Drawing nr. 122-658773

## Automatic production

MDM LIQUIDS /SLURRY

Drawing nr. 20-663701

## Automatic production

MDM LIQUIDS /SLURRY

Drawing nr. 20-663596

## Flexible Pipeloading system

MDM LIQUIDS /SLURRY

Drawing nr. 302-648587

## Automatic production

SEAFOOD MDM LIQUIDS /SLURRY ORGANS /MEAT

Drawing nr. 20-663795

Customize automation solutions

# The way forward for production efficiency



*Before investing in automation solutions, companies may experience inefficiency and lack of competitiveness due to outdated processes or strategies. Challenges like limited flexibility and slow adaptation to new technological developments can hinder production from being effective.*

*We address these critical issues with customized, technologically advanced solutions that ensure our customers remain competitive in a rapidly evolving industry.*

## Solutions for diverse Industries

At Erlinord, we specialize in the development and delivery of customized equipment for efficient handling and palletizing across a wide range of industries, including the meat and poultry, pet food, and fruit and vegetable sectors. Our expertise in robotic technology ensures precision and efficiency in the palletizing processes, helping businesses optimize their production lines.



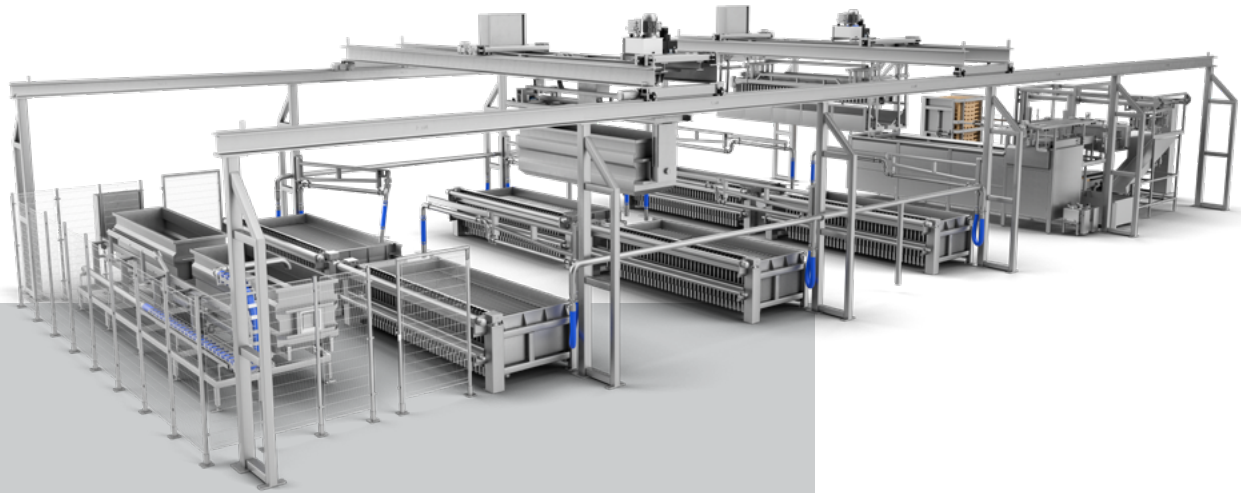

## Handling equipment

Maximize production efficiency and minimize production costs with automatic auxiliary equipment and handling solutions. Automating your production will also have a positive effect on safety, hygiene, and labor costs.

As the only all-in-one supplier of complete freezing, cooling, and heating solutions, we customize automation solutions for all processes from conveyor systems, crane rail constructions, pipe and pump loading systems, cranes, robots, stacking systems, palletizing conveyors, to stretch wrappers, etc.

You can choose manual, semi-, or fully automated equipment, or you can add modules to your existing facility to obtain an all-in-one solution that combines the thermal treatment you need with state-of-the-art handling equipment.



## Success stories

Erlinord has a long history of reliable service and quality, evidenced by our enduring customer relationships.

We deliver durable, evolving solutions in automation, making us a preferred partner. Beyond building machines, we create partnerships tailored to your specific needs and goals, establishing us as a leading provider of custom solutions that transform industrial processes.

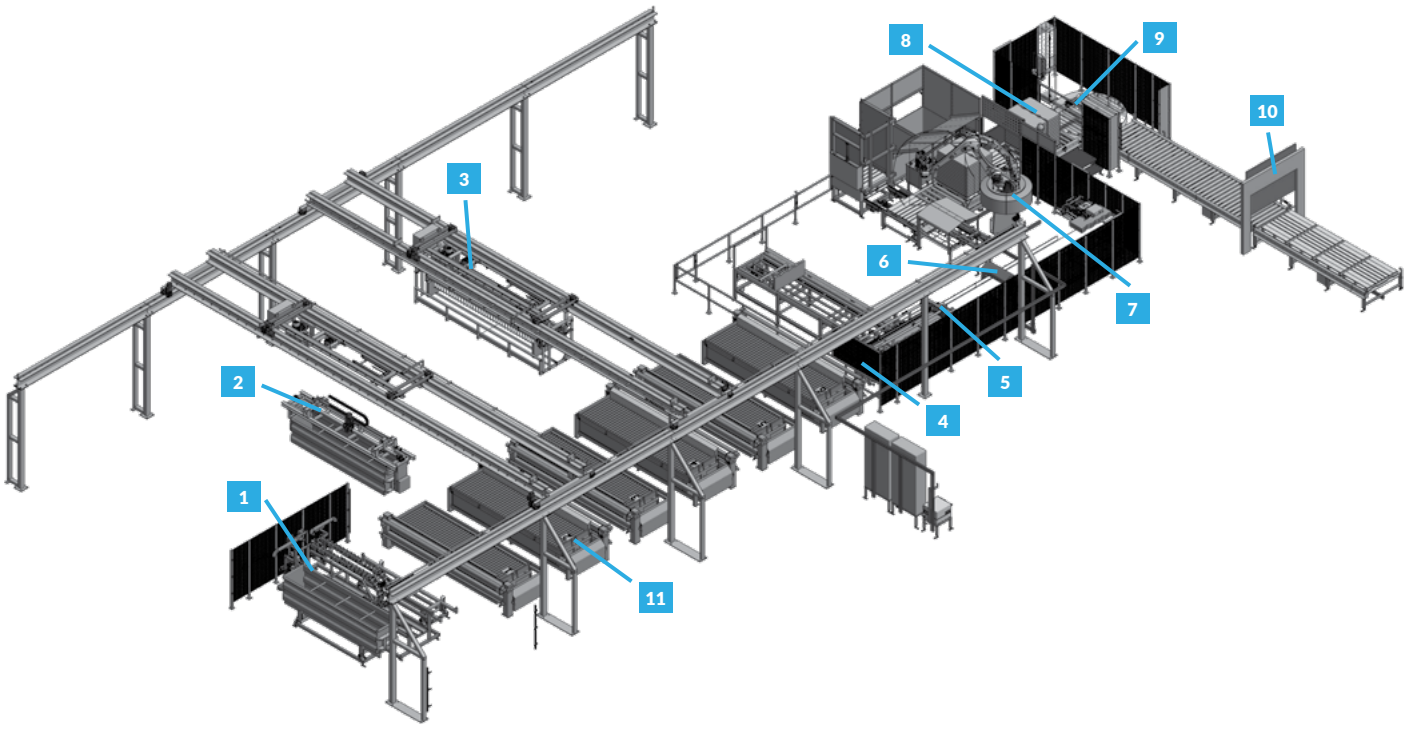

# Production line setup

Our handling equipment ensures smooth and efficient operations throughout the production process.

## 1 Loading container with scale

- Batch loading for plate freezers
- Fastest option on the market

## 2 Batch loading crane

## 3 Unloading crane unit

- Unloading a full plate freezer in less than a minute
- Max 2 operators for high capacity systems

## 4 Loading table & kipper

- 1 or 2 blocks at a time
- Flexibility for high capacity

## 5 Block cutter

- Cutting blocks in halves
- No manual handling block dividers

## 6 Metal detector

- Automatic QA system for metal detection
- Automatic internal control of system

## 7 Palletizing robot

- Denatur spray for PET food (US market)
- Full pallet scale
- Communication with label unit and SCADA system

## 8 Manual hood appliance station

## 9 Automatic pallet wrapping

- Inline system with no manual handling

## 10 Finished pallets wrapped and labelled entering cold storage area

## 11 Plate Freezers

## Facility

### Auxiliary equipment

Auxiliary equipment is designed to streamline your production in a highly hygienic and efficient manner

### Loading solutions

Loading equipment is designed using the latest technological developments.

### Unloading solutions

Customized systems ensure fast and simple unloading, and facilitate a very large capacity, helping you to boost production efficiency.

### Packaging solutions

Our systems guarantee extremely high levels of quality and safety for high-speed palletizing and packaging

# Vertical Solutions

*Our vertical solutions provide flexibility  
and high capacity, optimized for  
various industries.*



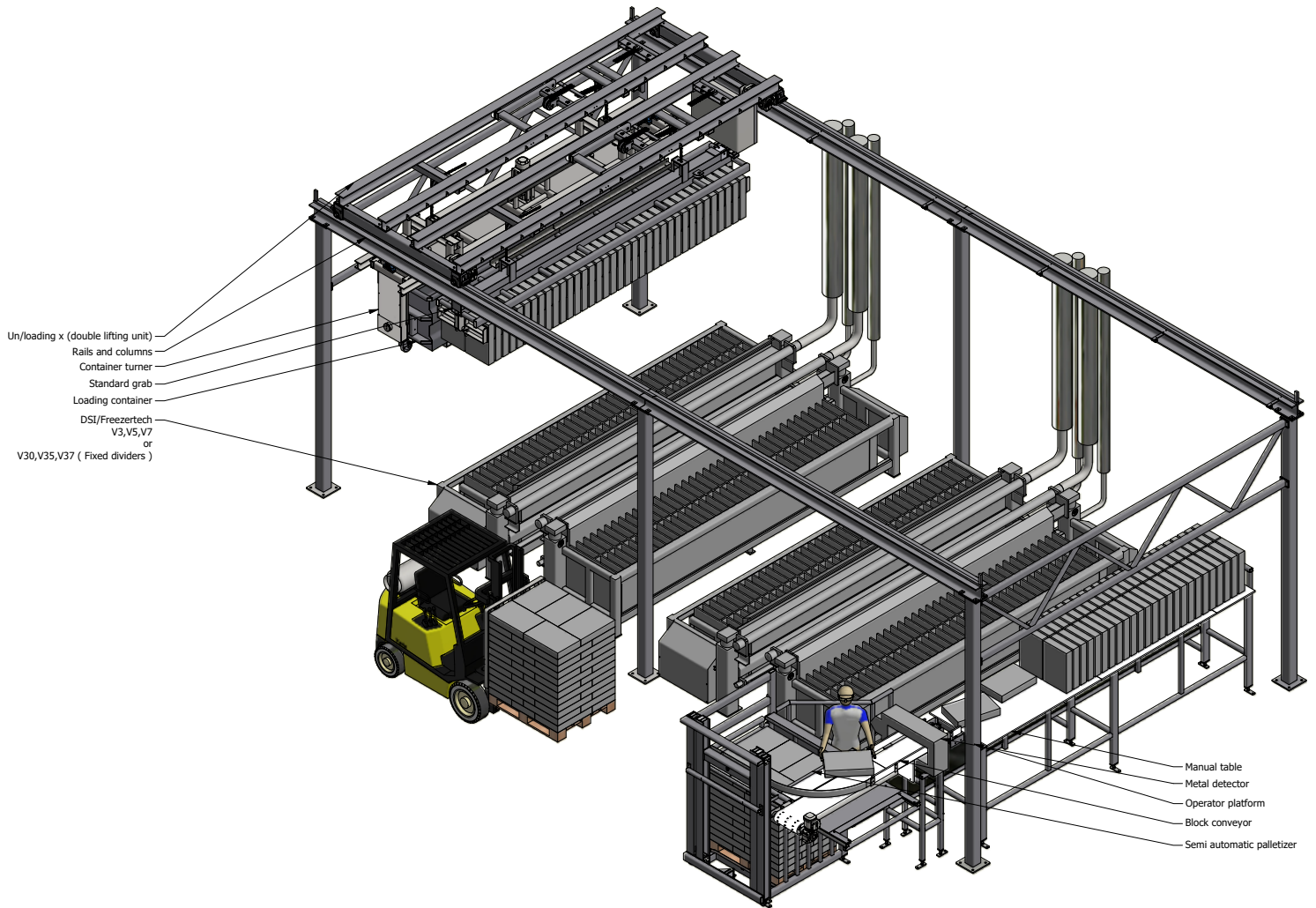

# Semi-Automatic

## Crane loading & unloading

*Semi automatic production with manual onloading table and semi automatic palletizer.*

### Cases based on 4 Freezers

- ▶ V3 36/75 Nh3 -38° C  
Cycle time 180 min  
Approx 42 Ton/24 hours  
Block size 1070x535x75 mm
- ▶ V5 36/75 Nh3 -38° C  
Cycle time 180 min  
Approx 36,1 Ton/24 hours  
Block size 820x600x75 mm
- ▶ V7 36/75 Nh3 -38° C  
Cycle time 180 min  
Approx 44,8 Ton/24 hours  
Block size 1220x500x75 mm

SEAFOOD

MDM

LIQUIDS /SLURRY

ORGANS

**Drawing nr. 122-657838**



Dimensions

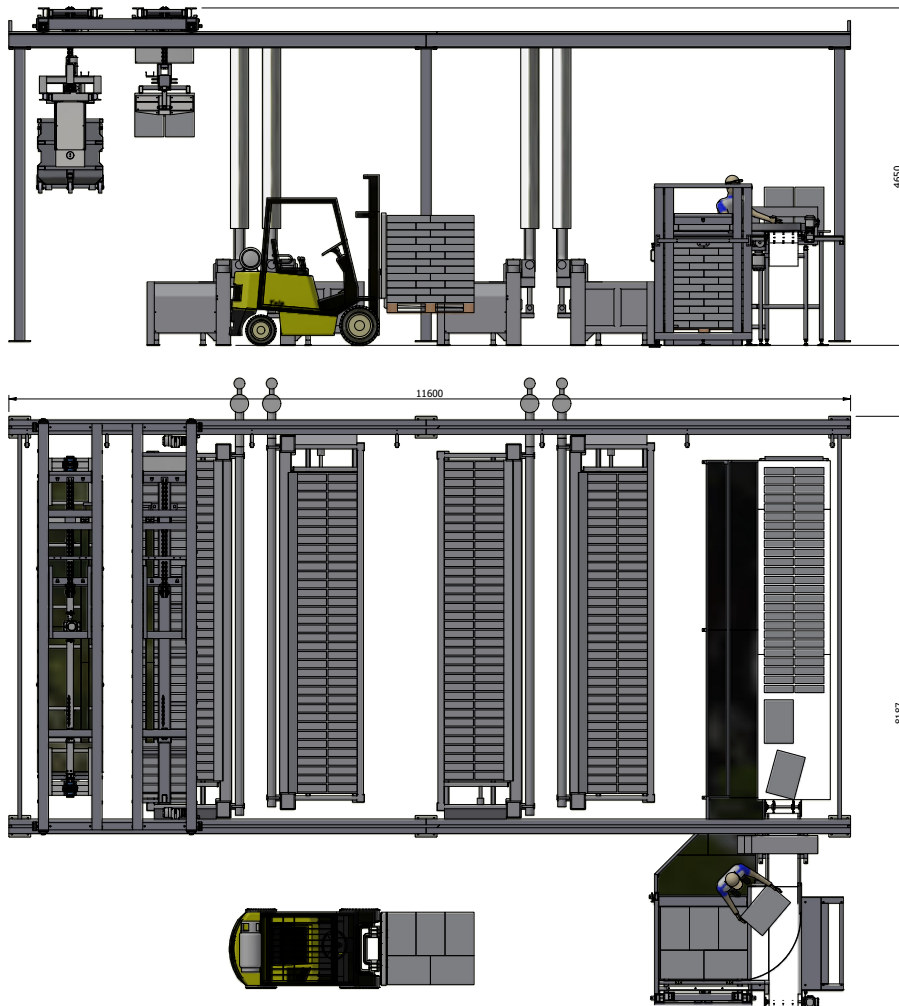



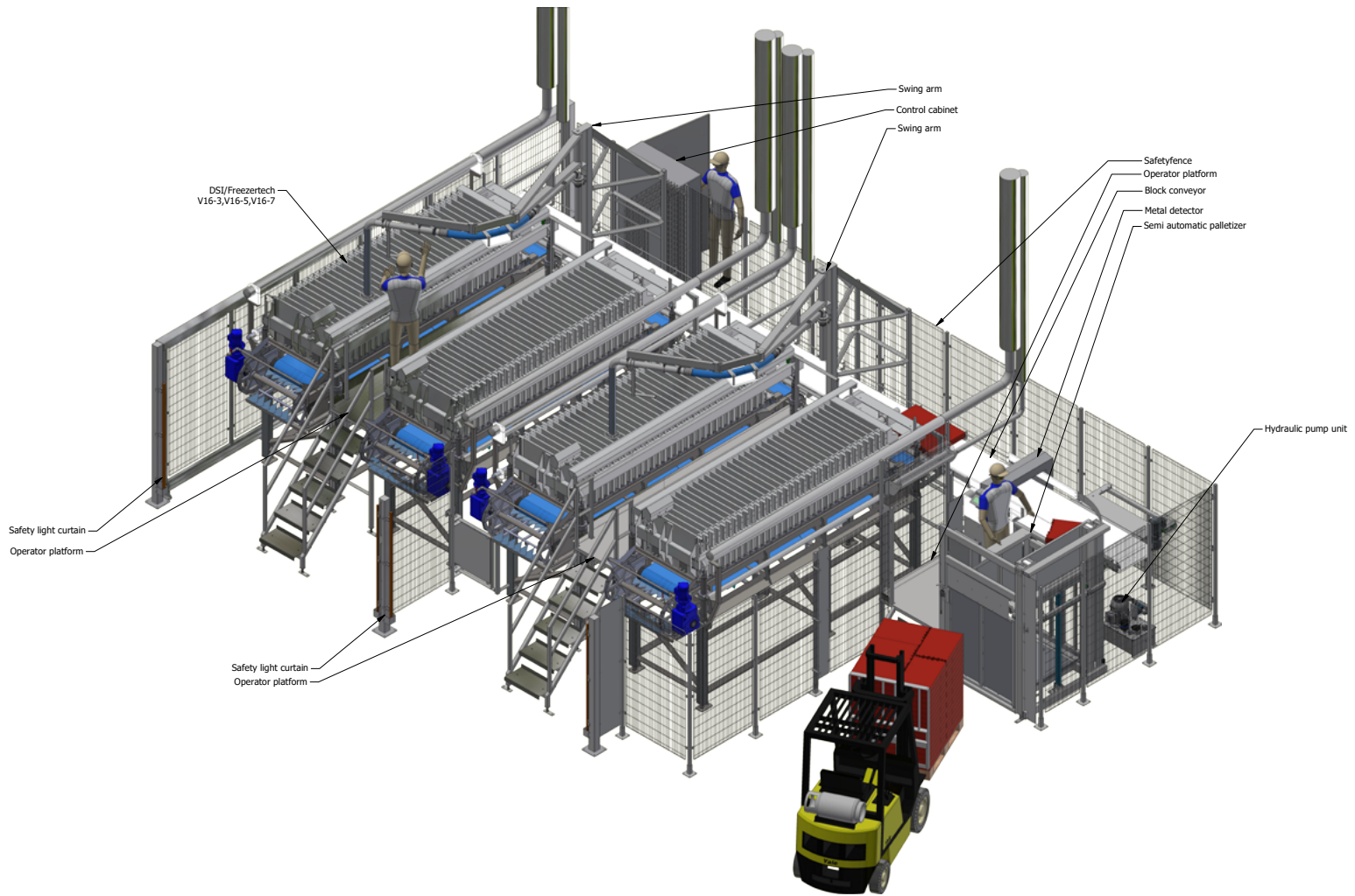

## Semi-Automatic Production

### V16 plate freezer solution

*Semi-automatic production with automatic V16 bottom discharge freezers, perfect for smaller production facilities where space for an overhead unloader is limited.*

#### Cases based on 4 Freezers

- ▶ V16-3 32/75 Nh3 -38° C  
Cycle time 180 min  
Approx 37 Ton/24 hours  
Block size 1070x530x75 mm
- ▶ V16-5 32/75 Nh3 -38° C  
Cycle time 180 min  
Approx 32,1 Ton/24 hours  
Block size 600x820x75 mm
- ▶ V16-7 32/75 Nh3 -38° C  
Cycle time 180 min  
Approx 39,8 Ton/24 hours  
Block size 1220x500x75 mm

MDM

LIQUIDS / SLURRY

**Drawing nr. 122-657843**

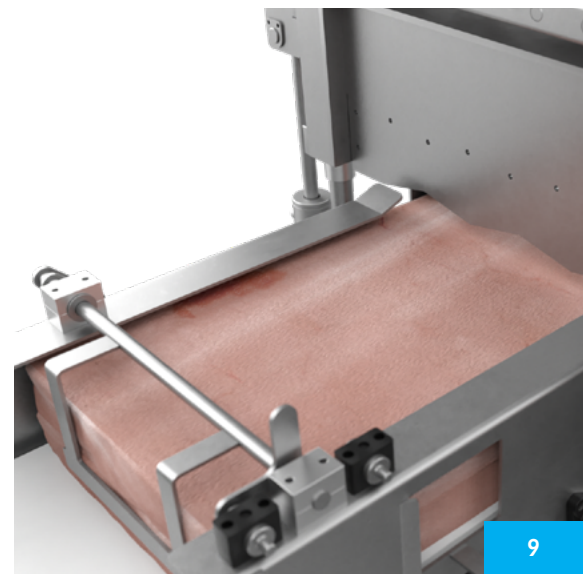

Dimensions

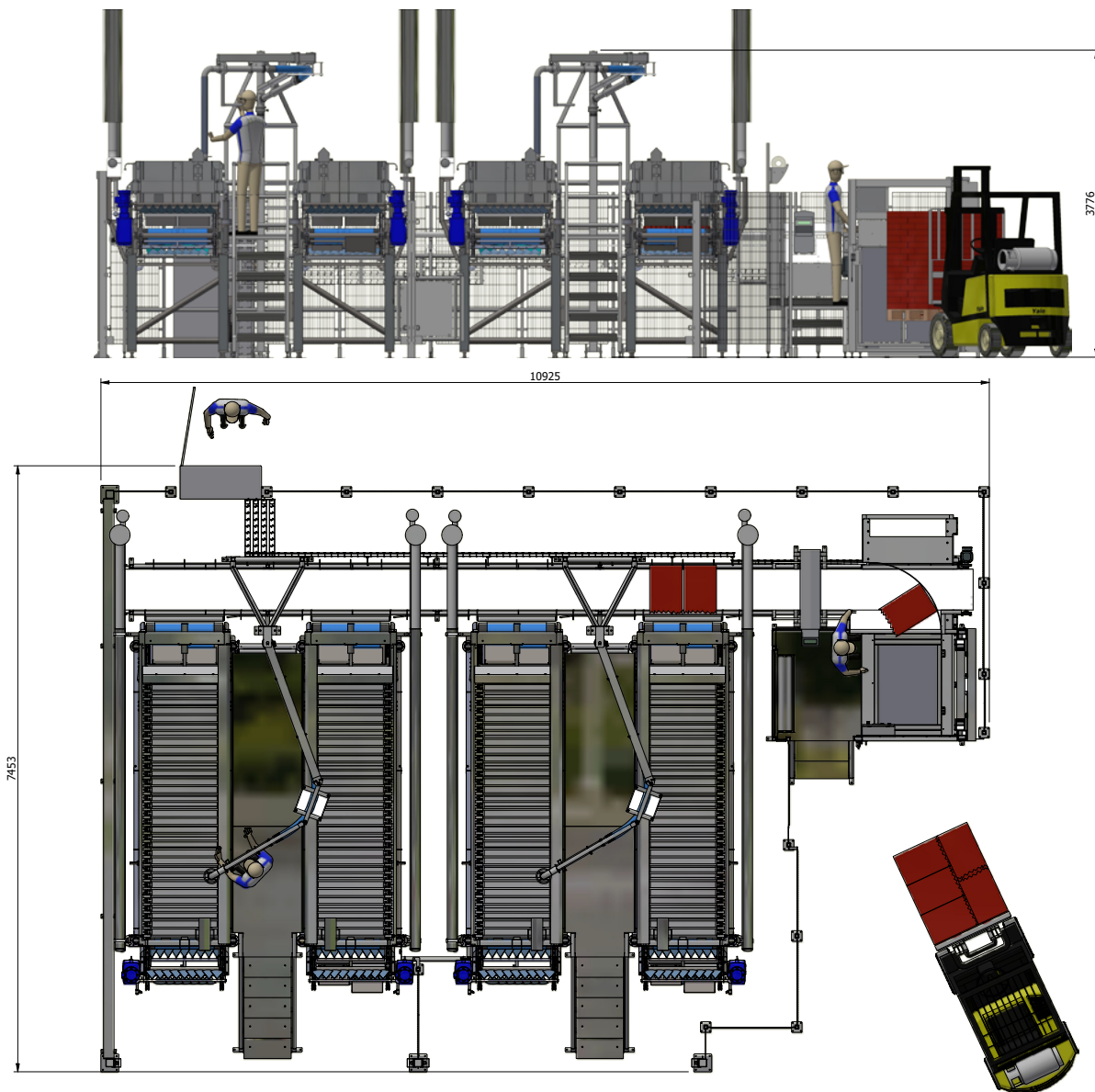

Follow Us | [YouTube](#) [in](#) [f](#)  
Erlinord.com

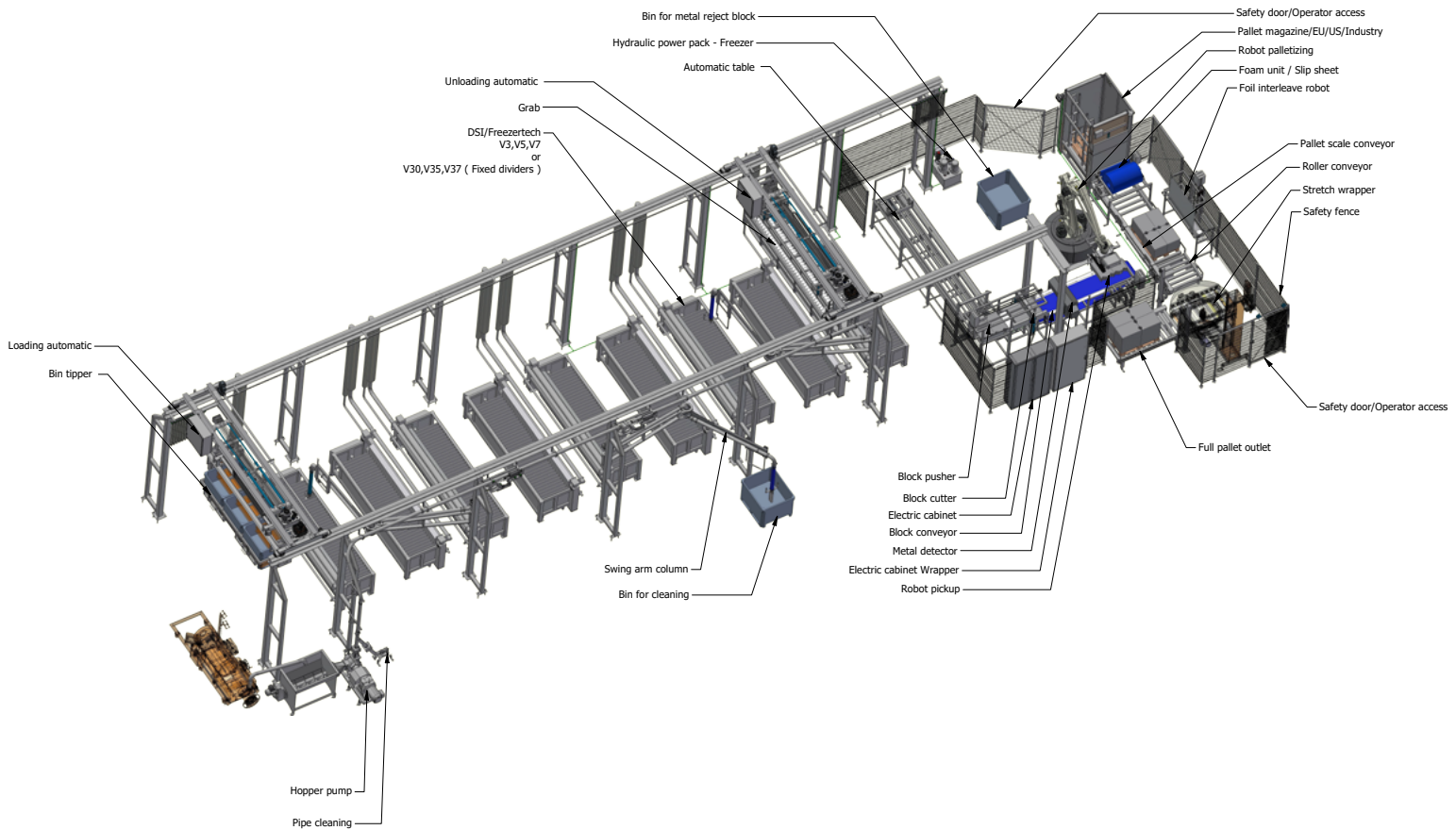

## Semi-Automatic Production

### Crane loading & Pump loading

*Semi-automatic production with automatic robot palletizing. Automatic pallet feed and full pallet wrapper. Filling arms for pumpable products with pig cleaning and a bin tipper for non-pumpable products.*

#### Cases based on 9 Freezers

- ▶ V3 26/75 Nh3 -38° C  
Cycle time 180 min  
Approx 68,3 Ton/24 hours  
Block size 1070x535x75 mm
- ▶ V5 26/75 Nh3 -38° C  
Cycle time 180 min  
Approx 58,7 Ton/24 hours  
Block size 600x820x75 mm
- ▶ V7 26/75 Nh3 -38° C  
Cycle time 180 min  
Approx 72,7 Ton/24 hours  
Block size 1220x500x75 mm

SEAFOOD

MDM

LIQUIDS /SLURRY

ORGANS

Drawing nr. 122-659020

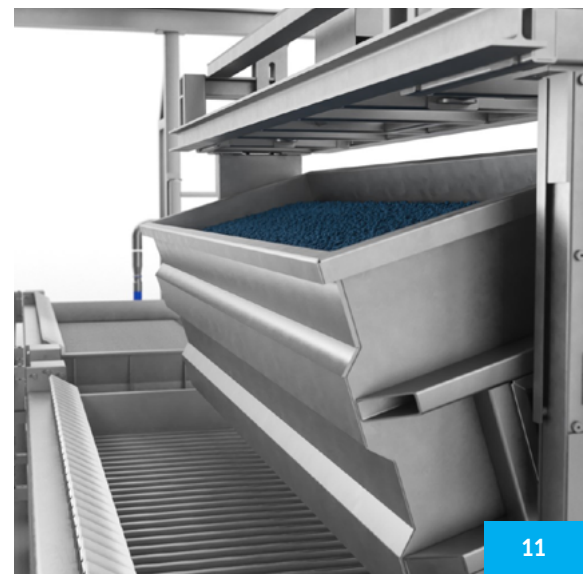

Dimensions

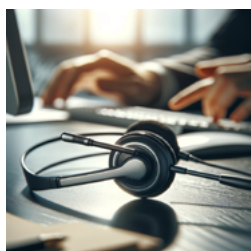
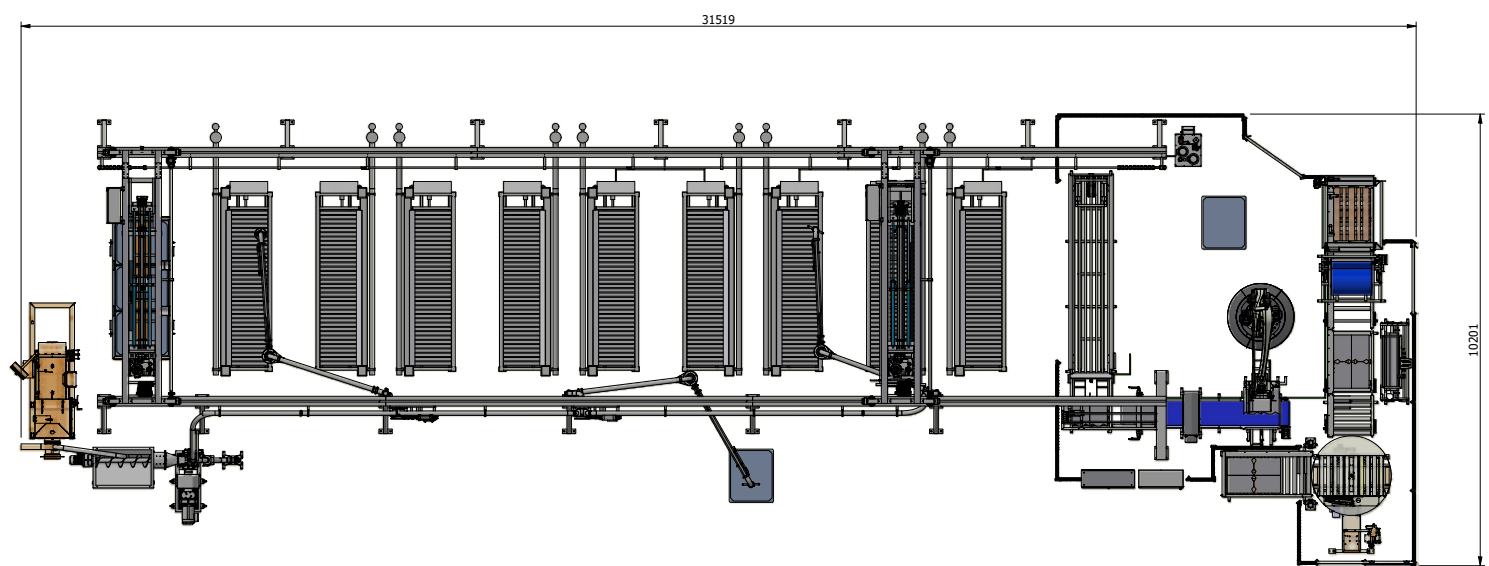
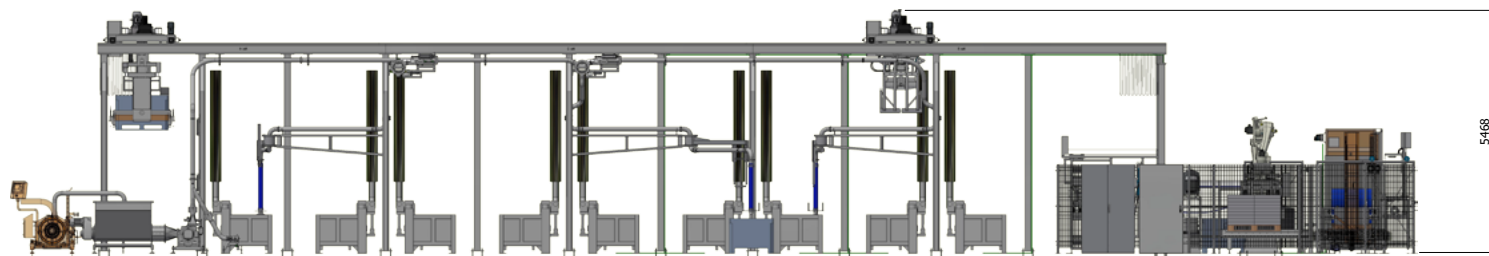

# Worldwide Service & support

Get in touch with the people behind Erlinord.  
We're here to help you find the right solutions.

[www.erlinord.com](http://www.erlinord.com)

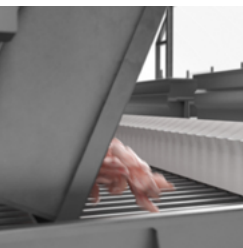

Thomas Uldall Jørgensen  
CEO/ Part owner  
+45 20718820  
[tuj@erlinord.com](mailto:tuj@erlinord.com)



Lasse K. Jensen  
Spare parts & service manager  
+45 2262 5143  
[aftersales@erlinord.com](mailto:aftersales@erlinord.com)



Count on our contribution

# Automate

Your production

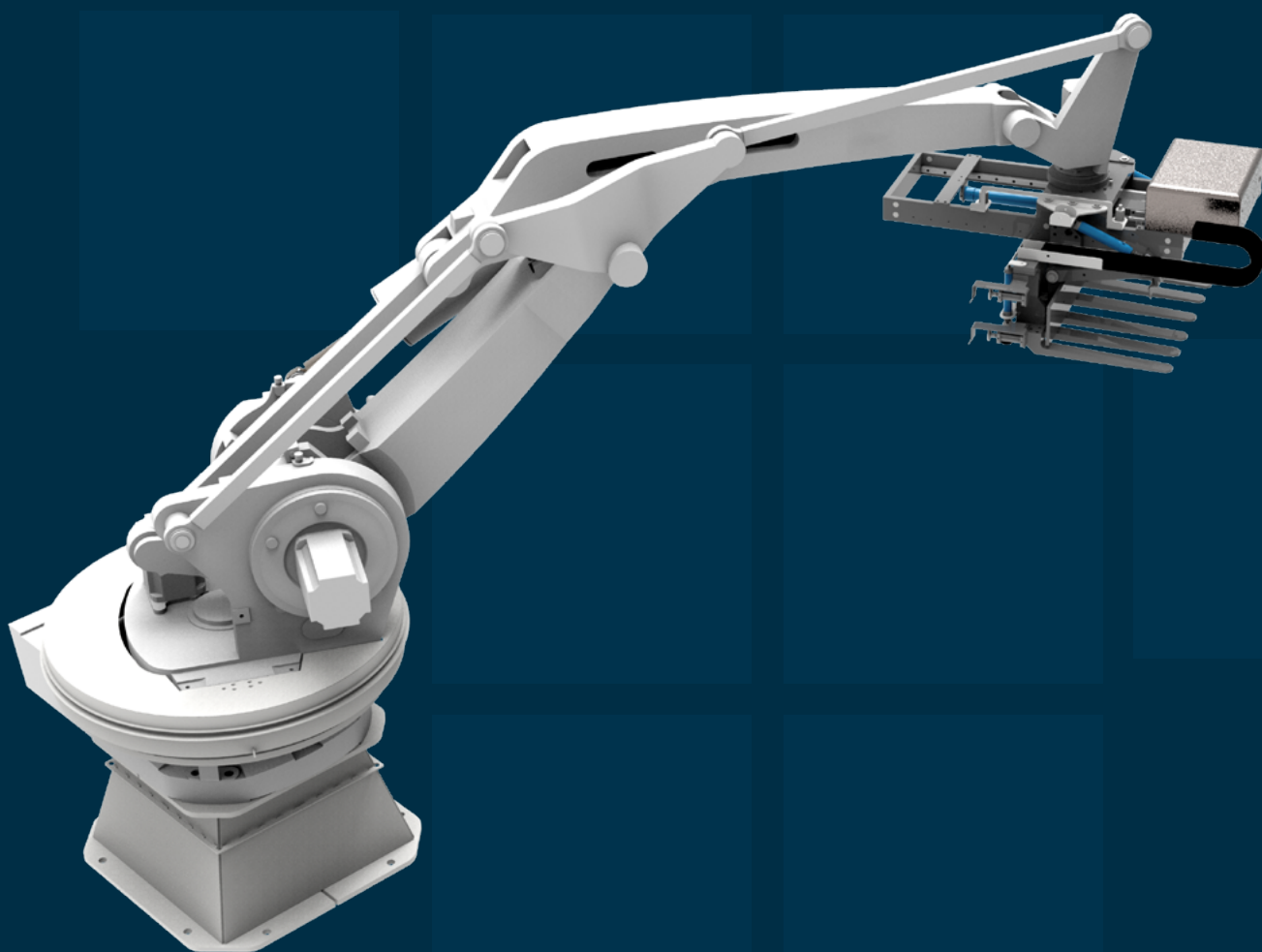

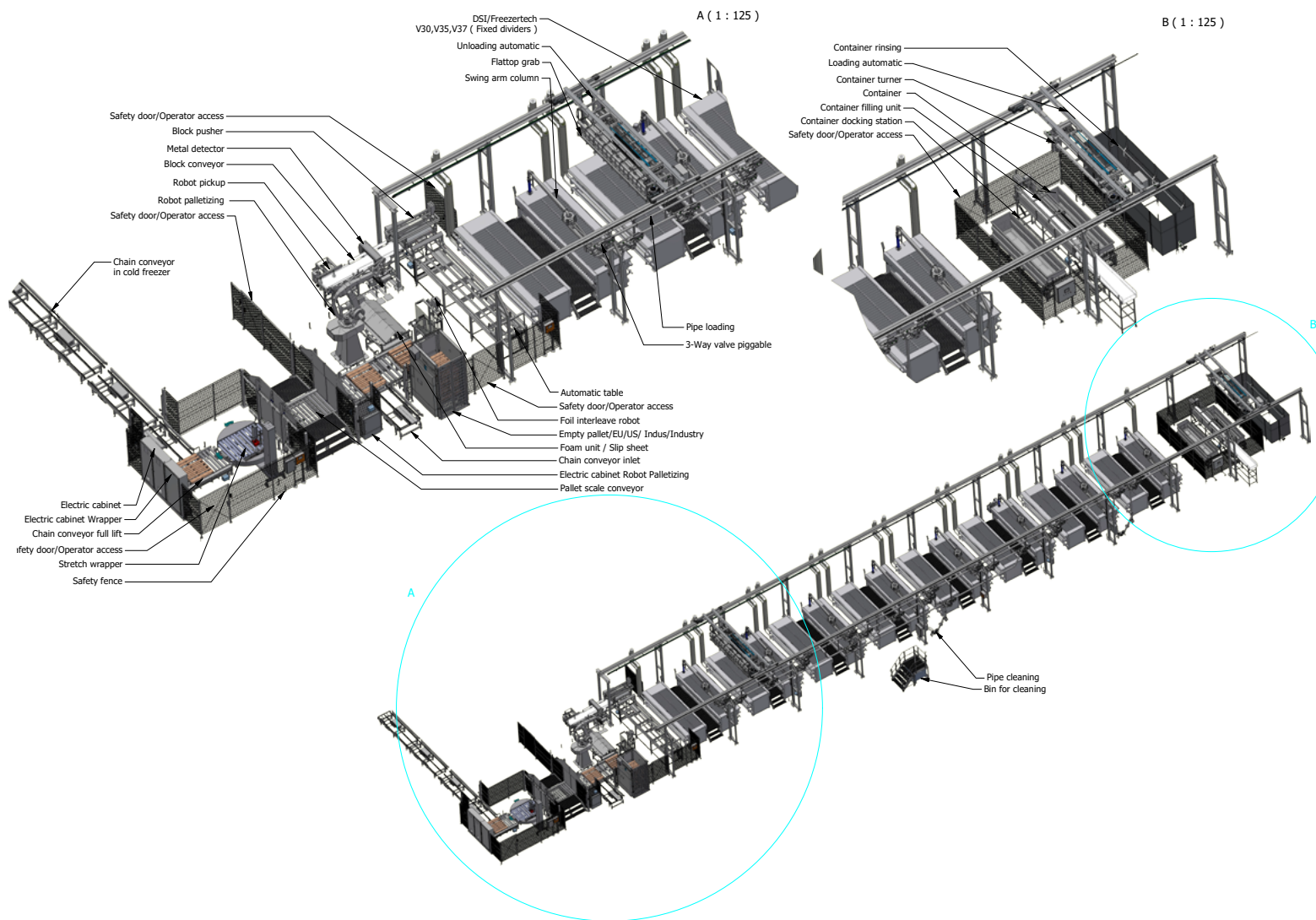

## Semi-Automatic Production

### Crane loading & Pump loading

*Semi-automatic production with automatic robot palletizing. Bag station and hygienic rinsing station for optimal hygiene in human consumption production.*

#### Cases based on 16 Freezers

- ▶ V37 36 station flat top freezers.
- Block size 1220 x 500 x 100 mm.
- Block weight 51,8kg.
- Cycle time 240 min.
- Capacity pr day pr. freezer 11.200kg/24 hours
- Capacity 16 freezers 179.200kg/24 Hours

- SEAFOOD
- MDM
- LIQUIDS /SLURRY
- ORGANS

**Drawing nr. 122-659023**



Dimensions

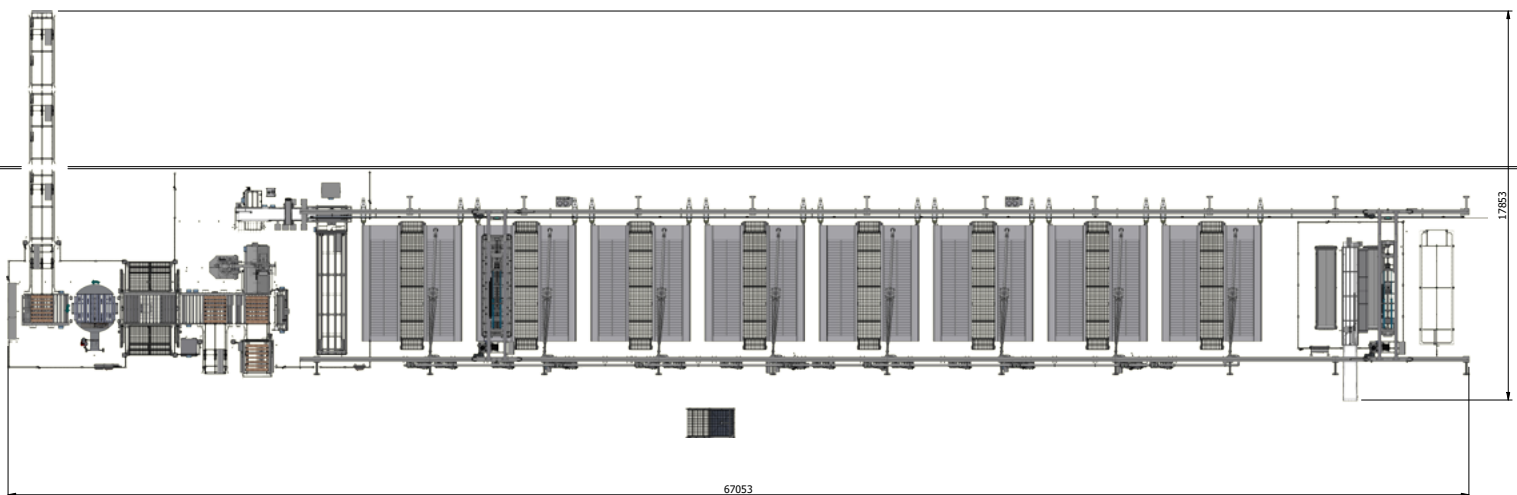

Follow Us |   

Erlinord.com

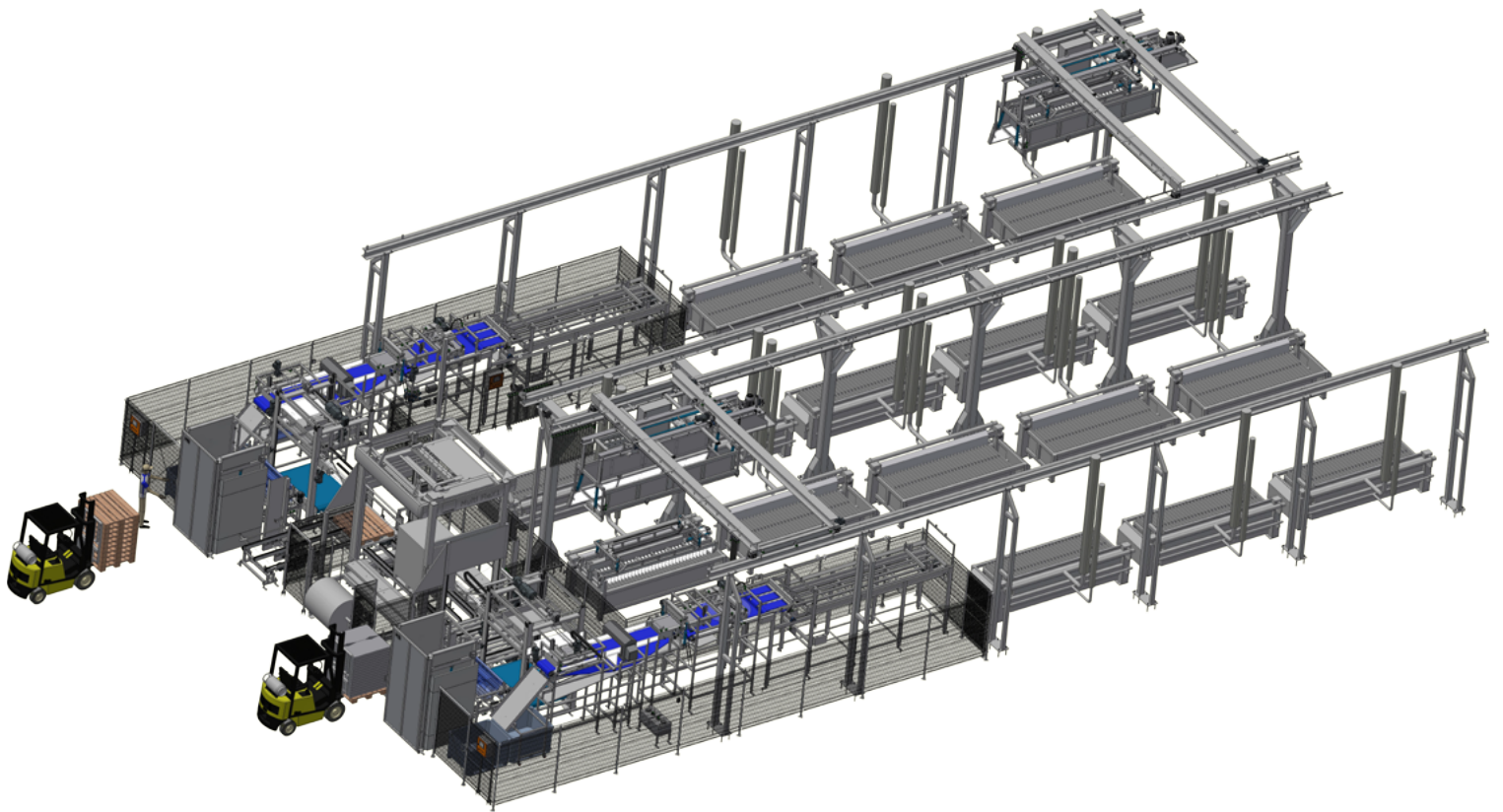

# Semi-Automatic production

Pumpable and whole organ products

## Cases based on 16 Freezers

- ▶ V3 32/75 Nh3 -38° C  
Cycle time 180 min  
Approx 148 Ton/24 hours  
Block size 1070x535x75 mm
- ▶ V5 32/75 Nh3 -38° C  
Cycle time 180 min  
Approx 128,4 Ton/24 hours  
Block size 600x820x75 mm
- ▶ V7 32/75 Nh3 -38° C  
Cycle time 180 min  
Approx 159,2 Ton/24 hours  
Block size 1220x500x75 mm

SEAFOOD

MDM

LIQUIDS /SLURRY

ORGANS/MEAT

Drawing nr. 122-657765





Dimensions

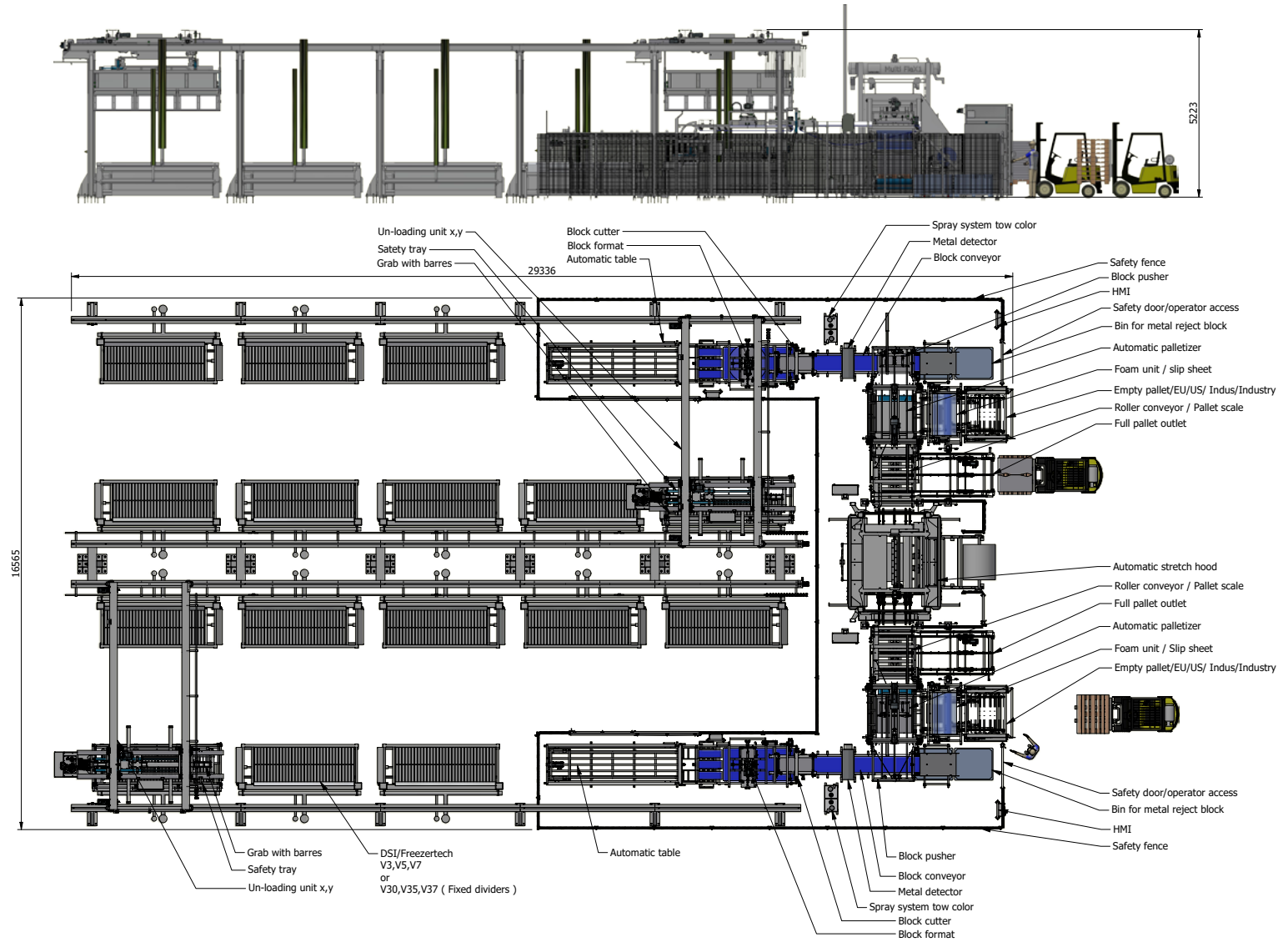

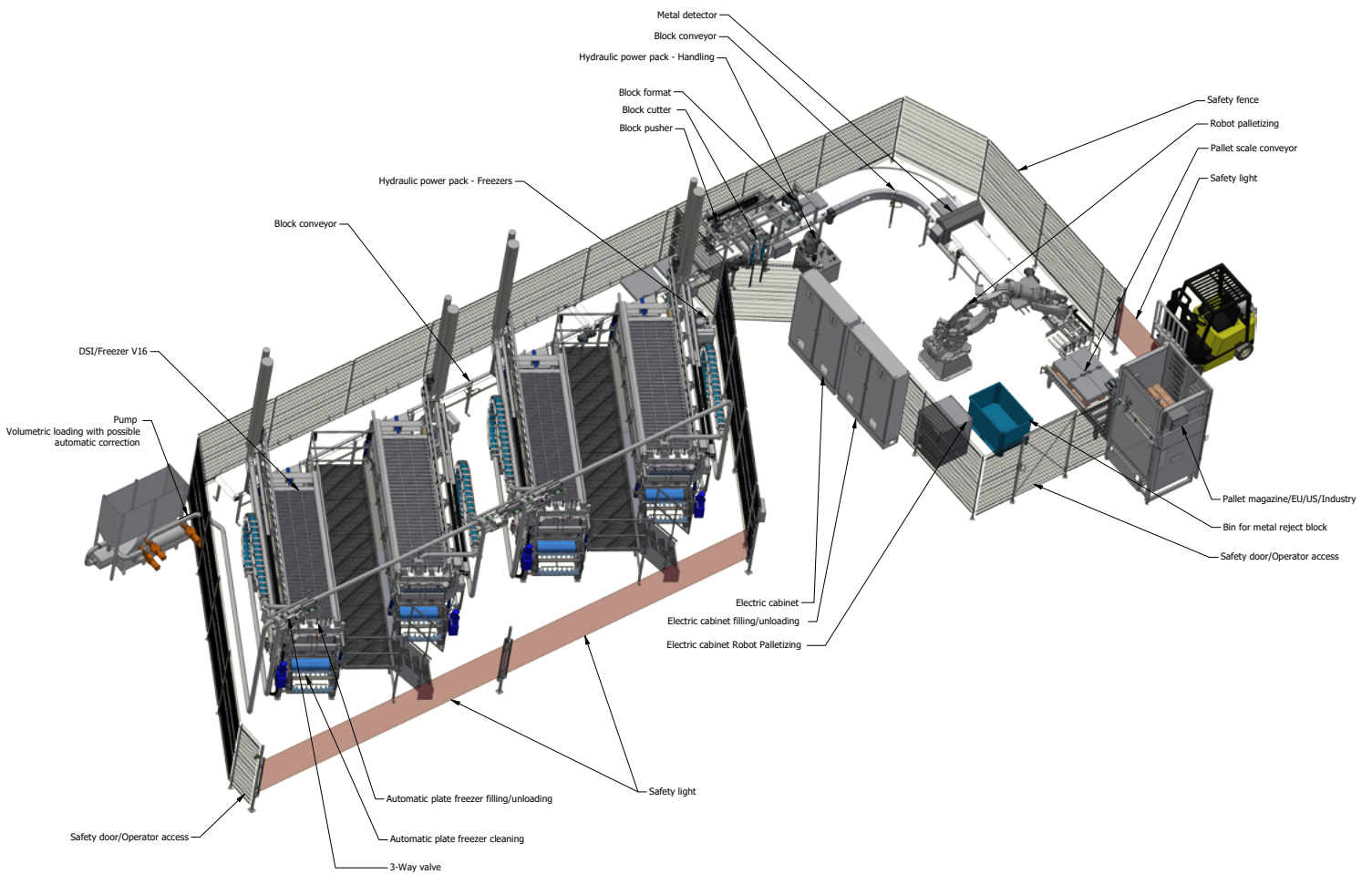

## Full- automatic production

### Pumpable products

*Fully automatic lights-out production based on automatic V16 freezers with automatic filling, discharge, and cleaning.*

*Fully automatic robot palletizing, capable of packing full and half blocks thanks to the incorporated block-cutter.*

#### Cases based on 4 Freezers

- ▶ V16 36/75 Nh3 -38° C
- Cycle time 180 min
- Approx 32,5 Ton/24 hours
- Block size 2x 600x400x75 mm

MDM

LIQUIDS /SLURRY

**Drawing nr. 122-656856**



Dimensions

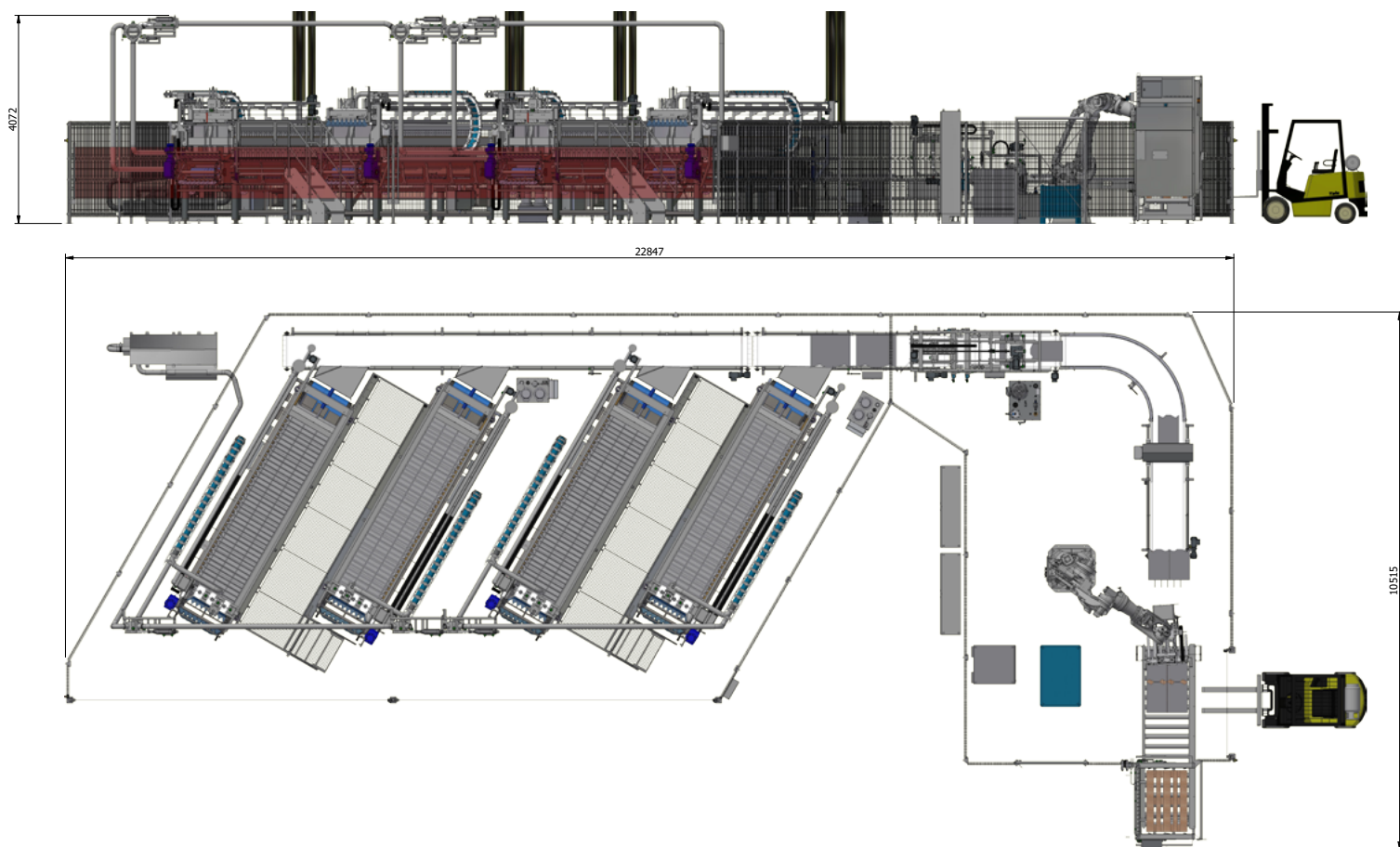

Follow Us | [YouTube](#) [LinkedIn](#) [Facebook](#)

Erlinord.com

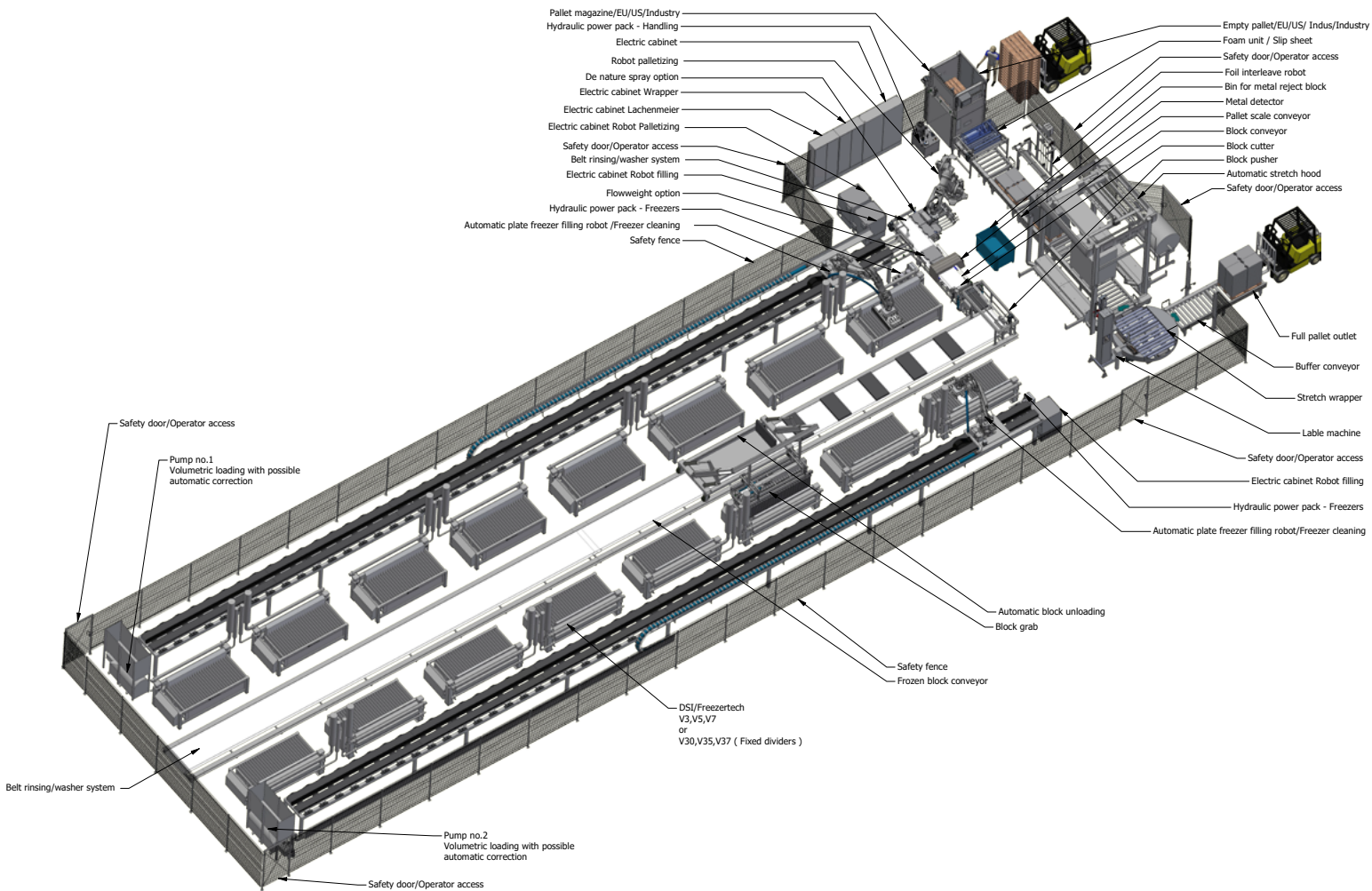

## Full- automatic production

### Pumpable products

#### Cases based on 16 Freezers

- ▶ V3 26/75 Nh3 -38° C  
Cycle time 180 min  
Approx 121,3 Ton/24 hours  
Block size 1070x535x75 mm
- ▶ V5 26/75 Nh3 -38° C  
Cycle time 180 min  
Approx 104,3 Ton/24 hours  
Block size 600x820x75 mm
- ▶ V7 26/75 Nh3 -38° C  
Cycle time 180 min  
Approx 129,3 Ton/24 hours  
Block size 1220x500x75 mm

MDM

LIQUIDS /SLURRY

Drawing nr. 20-650448



Dimensions

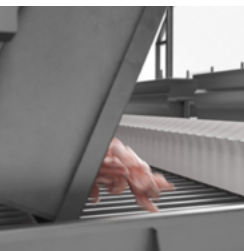
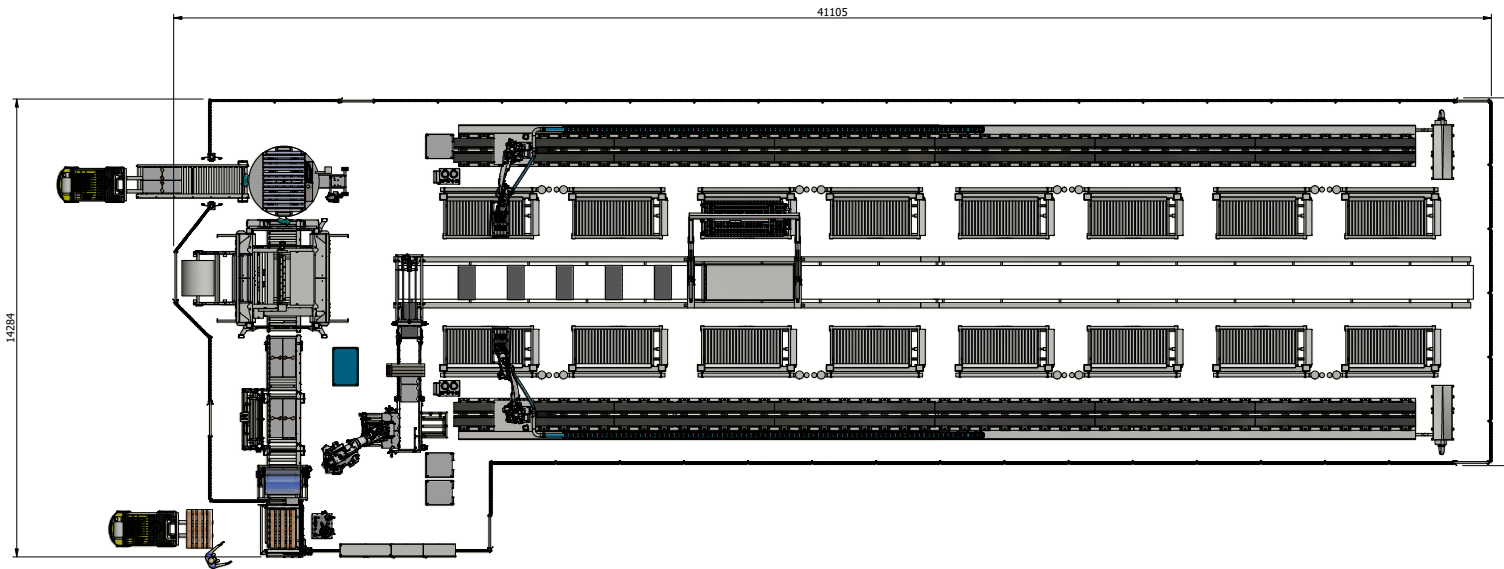
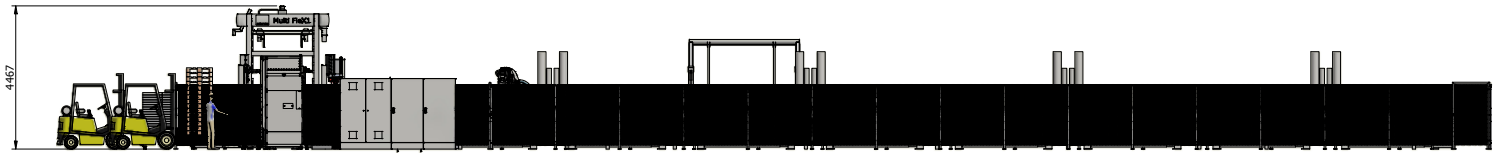

# Worldwide Service & support

Get in touch with the people behind Erlinord.  
We're here to help you find the right solutions.

[www.erlinord.com](http://www.erlinord.com)



Thomas Uldall Jørgensen  
CEO/ Part owner  
+45 20718820  
[tuj@erlinord.com](mailto:tuj@erlinord.com)



Lasse K. Jensen  
Spare parts & service manager  
+45 2262 5143  
[aftersales@erlinord.com](mailto:aftersales@erlinord.com)



# Horizontal Solutions

*Our horizontal solutions ensure efficient, high-volume handling with precise control, tailored to optimize workflows across different industries.*



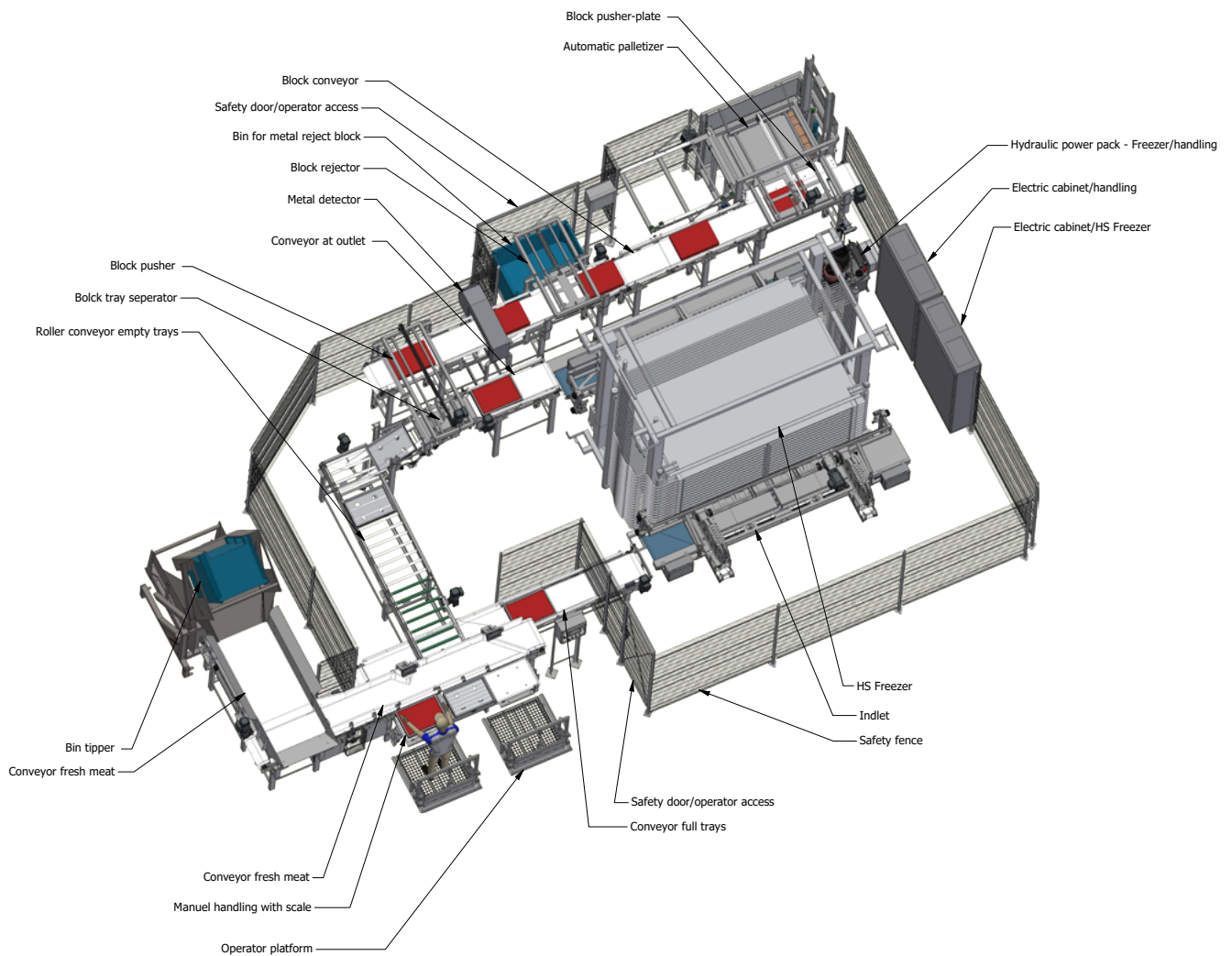

## Automatic production

### Horizontal system

#### Cases based on 1 horisontal freezer

HS Freezer Nh3 -38° C

Cycle time 180 min

Approx 40 Ton/24 hours

Usp:

- Fix waight Blocks
- Trace ability

SEAFOOD

MDM

LIQUIDS /SLURRY

ORGANS/MEAT

Drawing nr. 122-658773



Dimensions

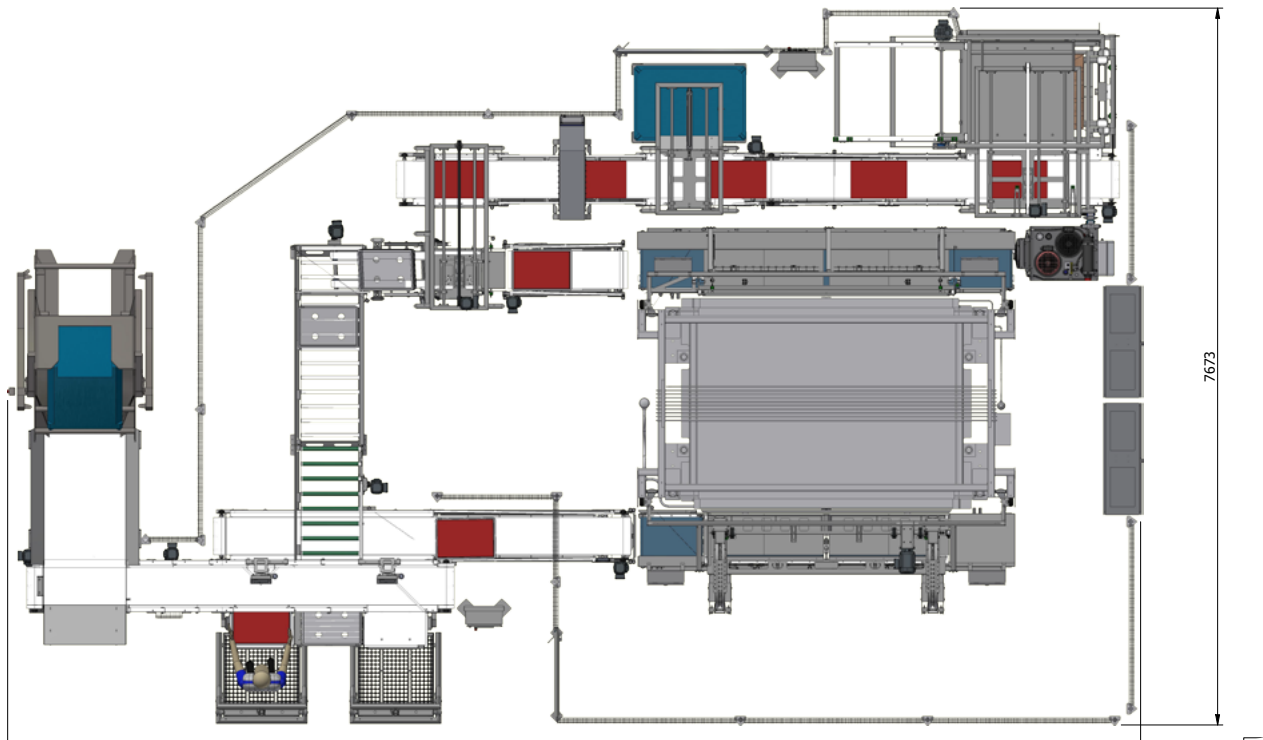
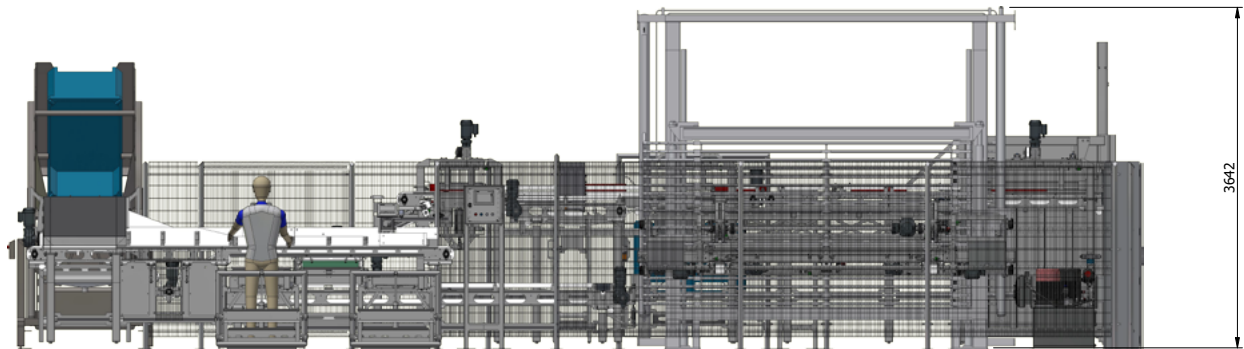

Follow Us |   

Erlinord.com



# Other Solutions

*We offer a range of specialized solutions designed to meet unique production challenges. From custom automation systems to tailored handling equipment, our solutions are built to enhance efficiency and flexibility, ensuring seamless integration into any production environment.*



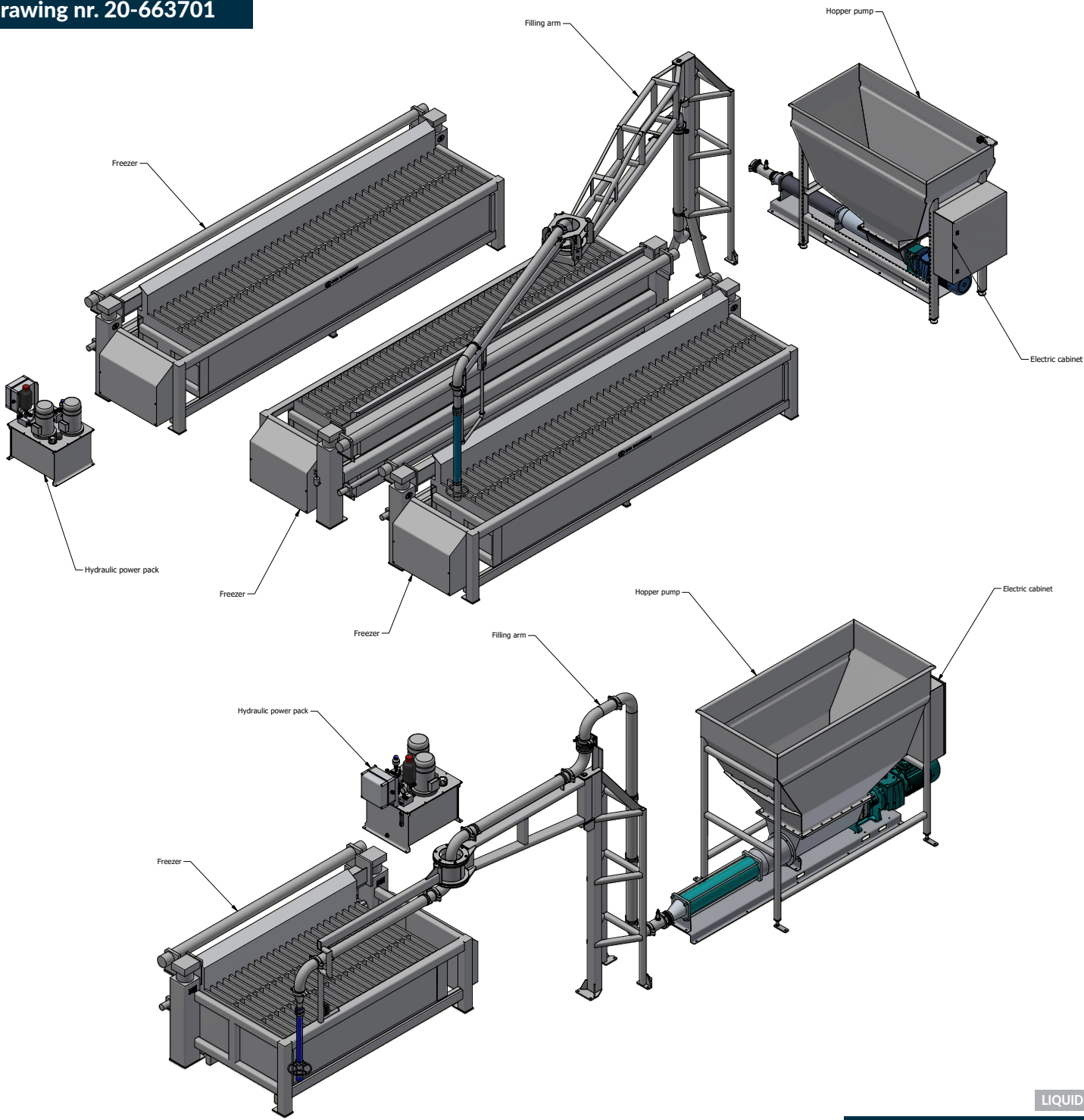

# Automatic production

## Hopper pump & Filling arm

### Cases based on 3 Freezers

- ▶ V5 44/75 B Nh3 -38° C
- Cycle time 180 min
- Approx 32,3 Ton/24 Hours
- Block Size 2x600x400x75

### Cases based on 1 Freezer

- ▶ V3 24/60 C Nh3 -38° C
- Cycle time 150 min
- Approx 6,5 Ton/24 Hours
- Block Size 3x347x535x60

Dimensions

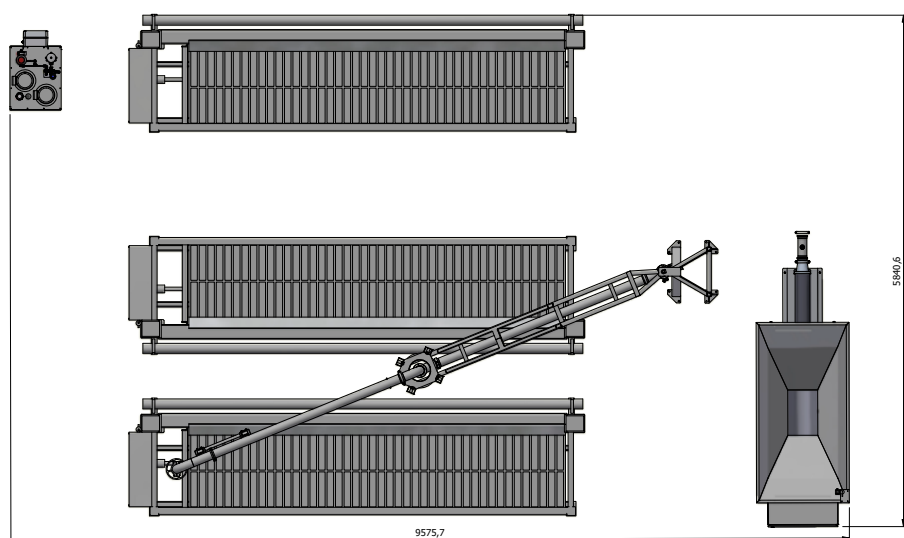
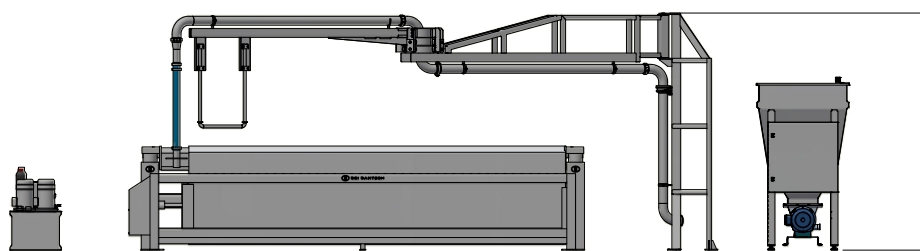

Drawing nr. 20-663596

Dimensions

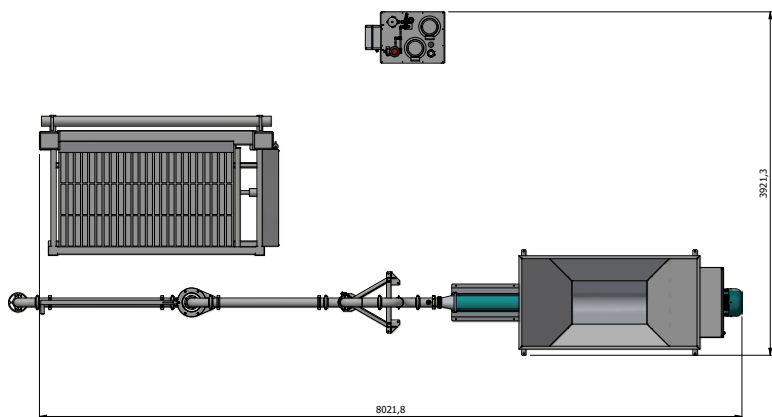
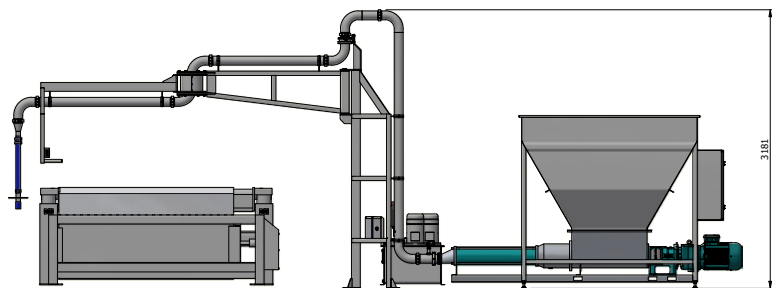

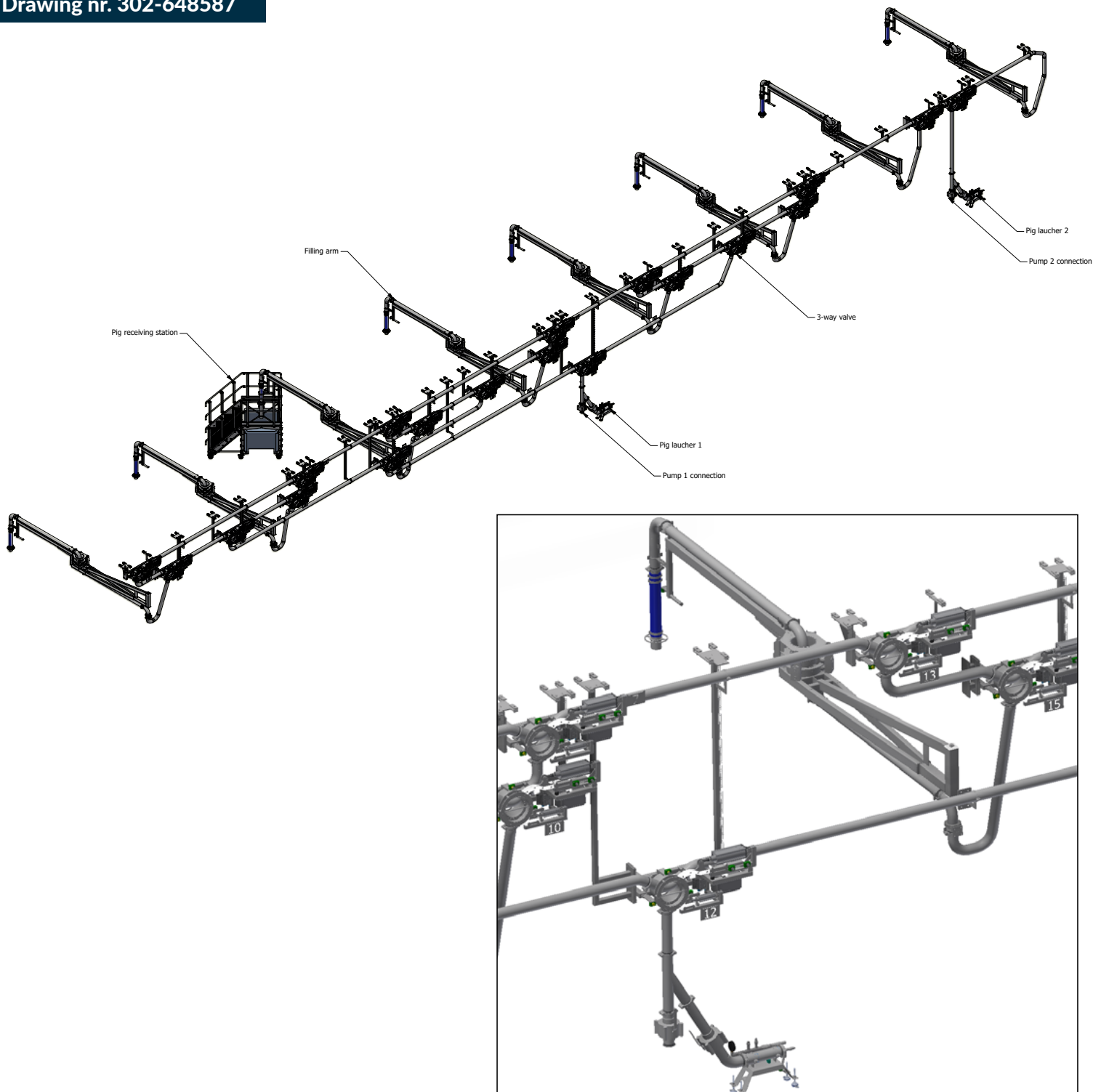

# Flexible Pipeloading system

Filling arms with 3-way Diverter valves

## Cases based on

- ▶ 3 x pump interfaces with pig cleaning
- ▶ 8 x filling arms
- ▶ Highly flexible piperoouting system with multiple products at the same time, No contermination.

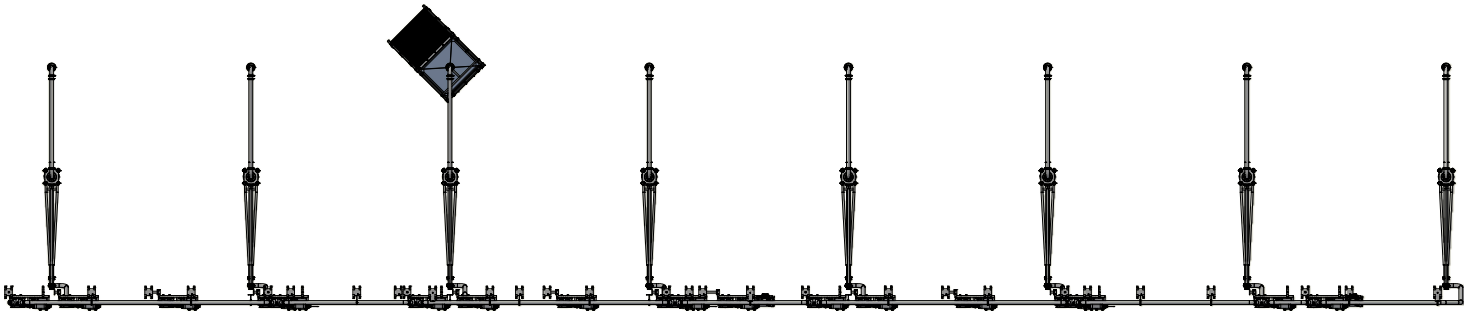
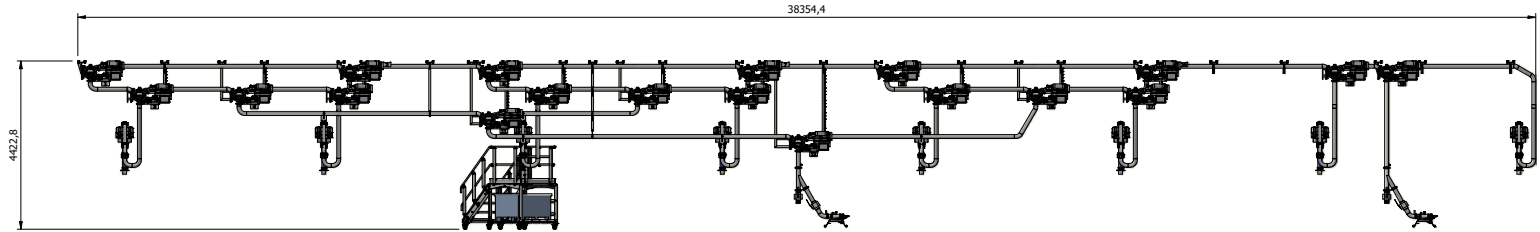

### Filling Arms with 3-Way Valve Setup

The pump will be connected to the system and will pump the product through a series of 3-way valves. This setup allows for a highly complex network of filling arms and multiple pumps in the same system. The maximum distance from the pump to the furthest filling arm is 20 meters due to pressure drop.

The system includes a pigging cleaning system, which is used to clear any remaining product in the pipes. The operator selects the filling arm that needs to be cleaned, and then connects the selected arm to the receiving station. A "pig" is launched from the launch station with compressed air and travels through the pipes to the receiving station.

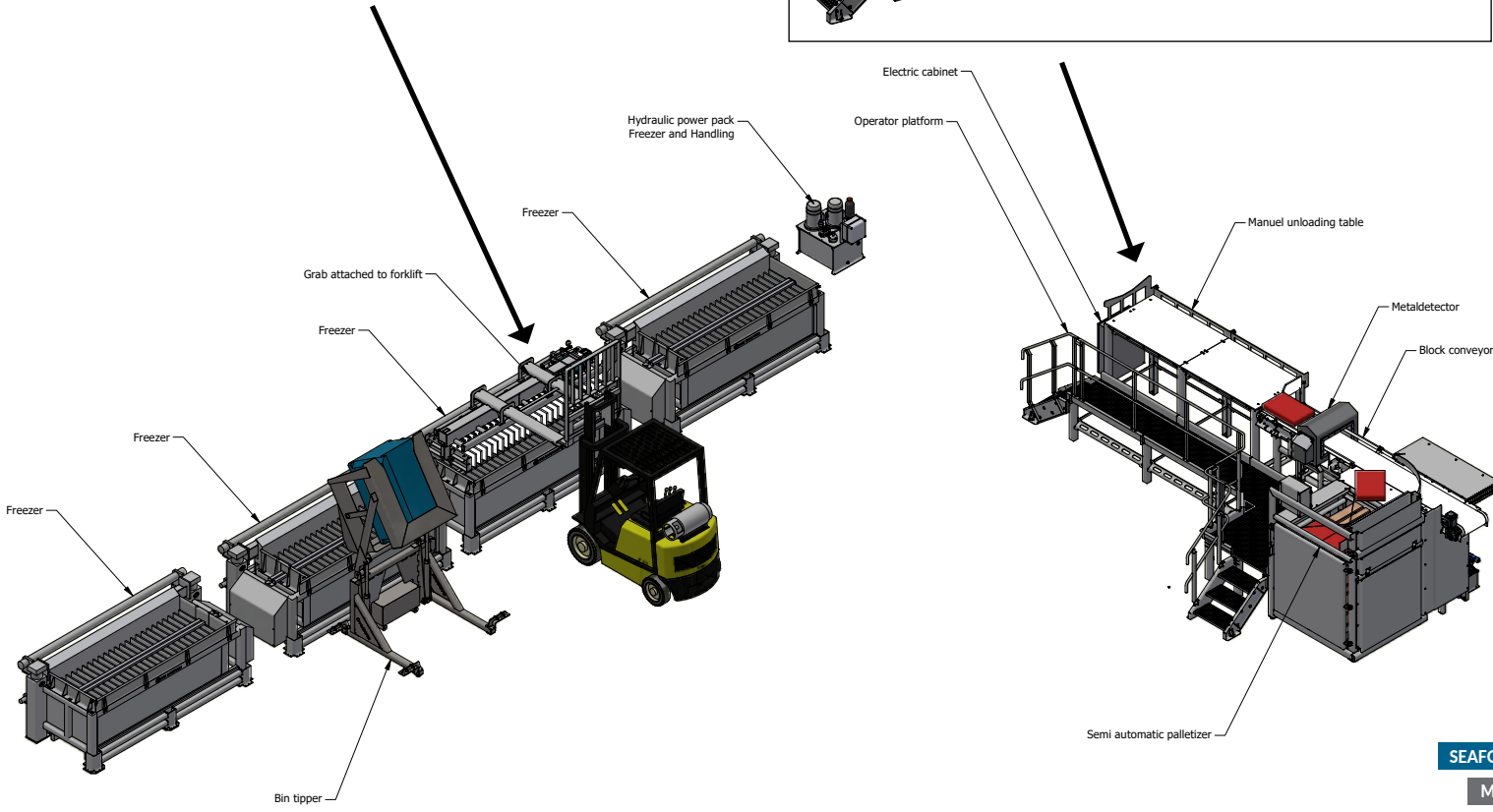
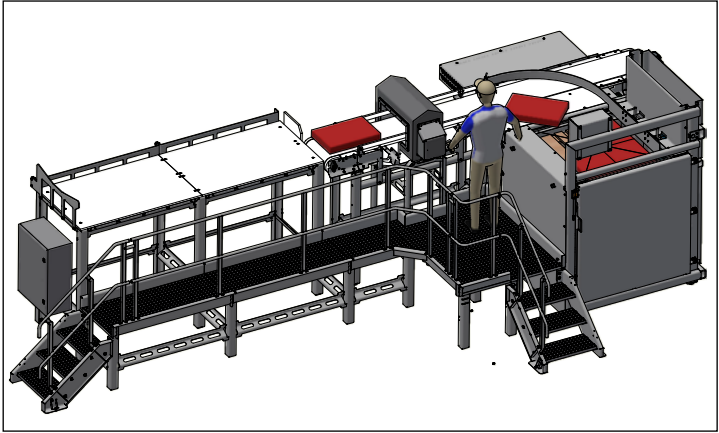
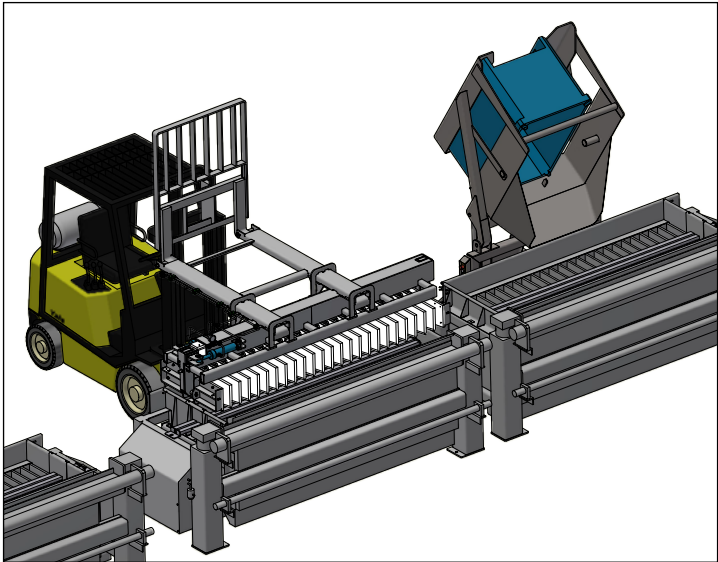

SEAFOOD

MDM

LIQUIDS /SLURRY

ORGANS/MEAT

**Drawing nr. 20-663795**

# Automatic production

## Bin tipper & Forklift

### Cases based on 4 Freezers

- ▶ V5 24/80 B Nh3 -38° C
- Cycle time 200 min
- Approx 22,5 Ton/24 hours
- Block Size 2x600x400x80



Dimensions

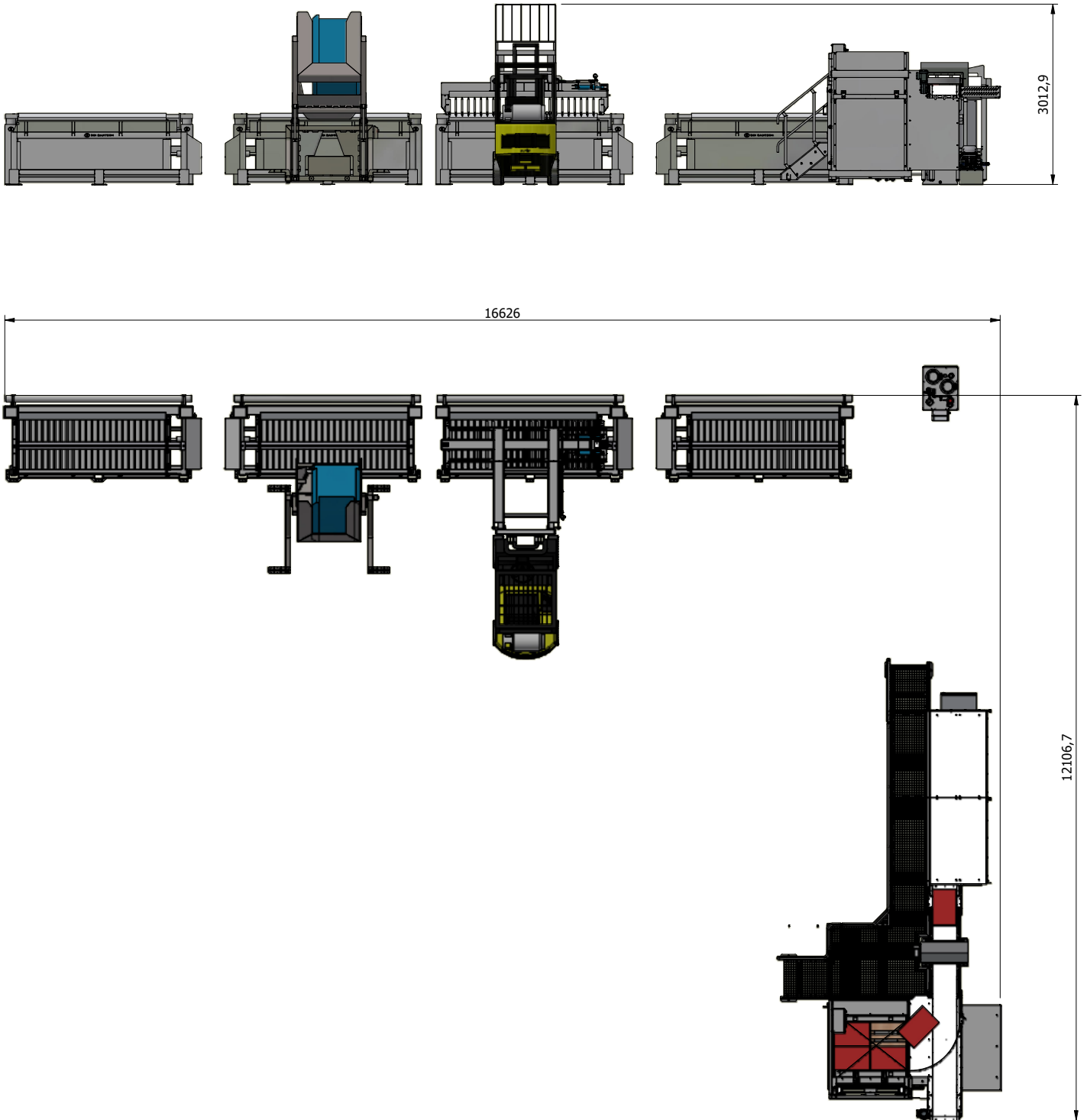



Tailored solutions since 1970

# All-in-one Automation solutions



## **Erlinord Automation Since we started**

Founded in 1970, Erlinord specializes in advanced palletizing systems and automation solutions for both pet and human consumption industries.

With strong global partnerships and a dedicated team of experienced professionals, we are ready to demonstrate our capabilities and workshops. Erlinord offers CE-certified machines, custom solutions on an hourly basis, and framework agreements for all bulk handling needs.



## Service agreements

Provide you with

- Highly skilled and dedicated specialists
- Minimized downtime
- Preventative inspection
- Extended equipment lifecycle
- Maintained high safety standard
- Environmental responsibility
- Genuine spare parts
- Special price on spare parts
- Special price on labour costs



## Service & Spare parts

Even the best equipment require regular service and neglecting that can consequently prove to be costly. Our service agreements will minimize production downtime, suit your operation and budget.

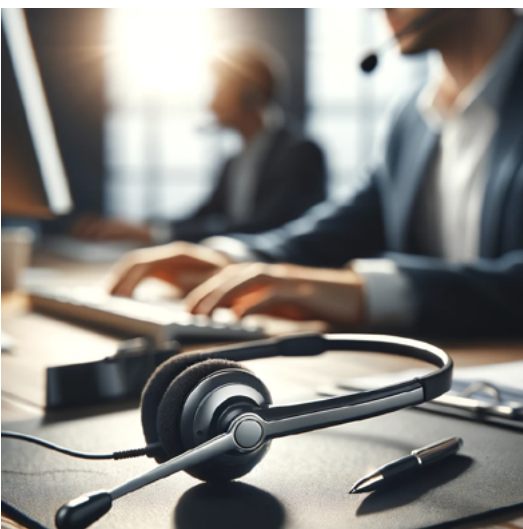

Lasse K. Jensen  
Spare parts & service manager  
+45 2262 5143  
aftersales@erlinord.com



# Worldwide Service & support

Get in touch with the people behind Erlinord.  
We're here to help you find the right solutions.

[www.erlinord.com](http://www.erlinord.com)

## Contact Information

### Erlinord Automation A/S

Tysklandsvej 4, 7100 Vejle  
Denmark  
cvr. 44596687  
[info@erlinord.com](mailto:info@erlinord.com)

Available Monday to Friday  
from 8.00 AM to 16.00PM (CET)  
Reach out to us at

**+45 75 88 20 88**



Thomas Uldall Jørgensen  
CEO/ Part owner  
+45 20718820  
[tuj@erlinord.com](mailto:tuj@erlinord.com)



Lasse K. Jensen  
Spare parts & service manager  
+45 2262 5143  
[aftersales@erlinord.com](mailto:aftersales@erlinord.com)



## Official Partner



**Nomad-foodtech**  
5 RUE DU HELDER 75009 PARIS 9  
[contact@nomad-foodtech.com](mailto:contact@nomad-foodtech.com)  
[www.nomad-foodtech.com](http://www.nomad-foodtech.com)



**Scan American Corporation**  
9505 N Congress Ave  
Kansas City, MO 64153  
[info@scanamcorp.com](mailto:info@scanamcorp.com)  
[www.scanamcorp.com](http://www.scanamcorp.com)



**DSI Dantech**  
Speditørvej 1, Building 39  
9000 Aalborg, Denmark  
[info@dsidantech.com](mailto:info@dsidantech.com)  
[www.dsidantech.com](http://www.dsidantech.com)

## Lokal Collaborators



**Juel Concept & Consulting**  
Barcelona, España  
[sales@juelconcept.com](mailto:sales@juelconcept.com)  
[www.juelconcept.com](http://www.juelconcept.com)



**Tech4foods**  
Tech4foods di Lorenzo Borsatti  
20154 Milano (Italia) · Via Mac Mahon, 40  
[lorenzo.borsatti@tech4foods.it](mailto:lorenzo.borsatti@tech4foods.it)  
[www.tech4foods.it](http://www.tech4foods.it)